



The Reliable Valve Source

Manufacturer of Newco, OIC, and Cooper Valves

Trinity Series Triple Offset Valves

Sizes: 3" thru 120"

DN: 80 thru 3000

ASME 150, 300, & 600

PN16, 25, 40, & 100

1.800.231.3505 • NewmansValve.com

by **Newco**



Newmans Triple Offset Valves feature standard Stellite body seats, robust laminated disc seats, and unique graphite stem bearing seals for exceptional service life.

Features and Benefits

- Triple Offset Design for Bi-directional Bubble Tight Shutoff
- Self Centering Disc
- Sealed bearing Design
- Stellite Body Seat Standard
- Blowout Proof Stem Option
- Firesafe Tested to API 607
- Available in a Wide Range of Materials and Configurations
 - WCB
 - 316 Stainless Steel
 - Monel
 - Hastelloy
 - Nickel - Aluminum - Bronze

Time Tested Performance from the Quality Valve Supplier

Newmans Triple Offset Valves are designed, manufactured and supplied from world class facilities serving the industrial processing, transmission, water treatment and power industries across the globe. The new Triple Offset Valves offer dependable, economical service for all applications that require proven performance and quality.

Superior Features come Together for Superior Service

Featuring the premium Triple Offset design, the Newmans TOV is a zero leakage valve in both directions utilizing a Stellite/316 SS metal seating surface carefully matched to provide superior sealing. The Triple Offset design uses three separate geometries of disc/stem orientation and rotation to accomplish bubble tight sealing. The proven conical seating feature allows Newmans Triple Offset Valve to operate with minimal torque, increased temperatures and longer life cycle. The disc and body seat engage with no rubbing of the seating components.

Our Commitment is to Your Success

The Newmans Triple Offset Valve meets or exceeds industry standards and is available in a wide range of pressures, materials and body configurations. Once again Newmans Valve is offering superior value and performance to our global customers. Contact your Newmans representative for more information on the new Triple Offset Valve Product line."

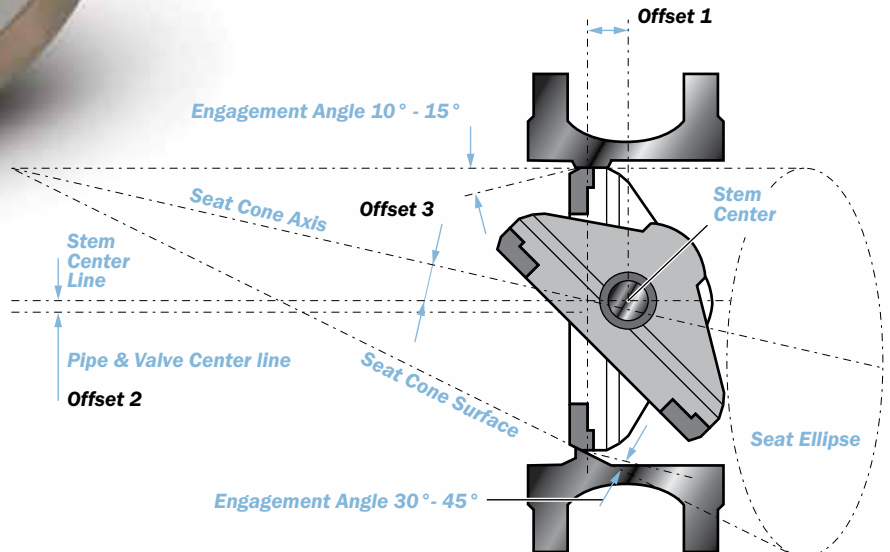

End Connections

- Wafer
- Lug
- Flanged
- Buttweld

Technical Demand Features

- Design and manufactured to ASME B16.34, API 609, ANSI B16.10, B16.5, & ISO 5752
- Test and Inspect to API 598
- Flange to ASME B16.5
- Face-to-Face to API 609 & DIN
- Firetest per API 607
- Materials to NACE Requirements
- Fugitive Emissions Tested to ISA-d59.3.0.01

Flanged Design

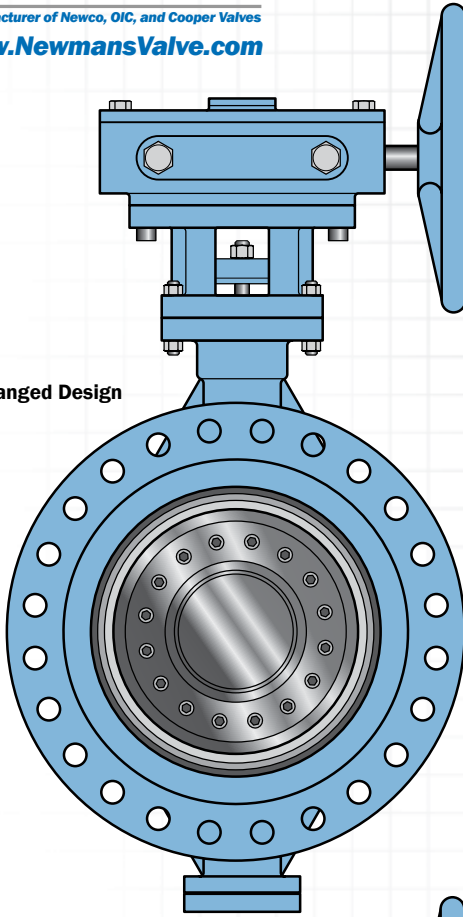

Lug Design

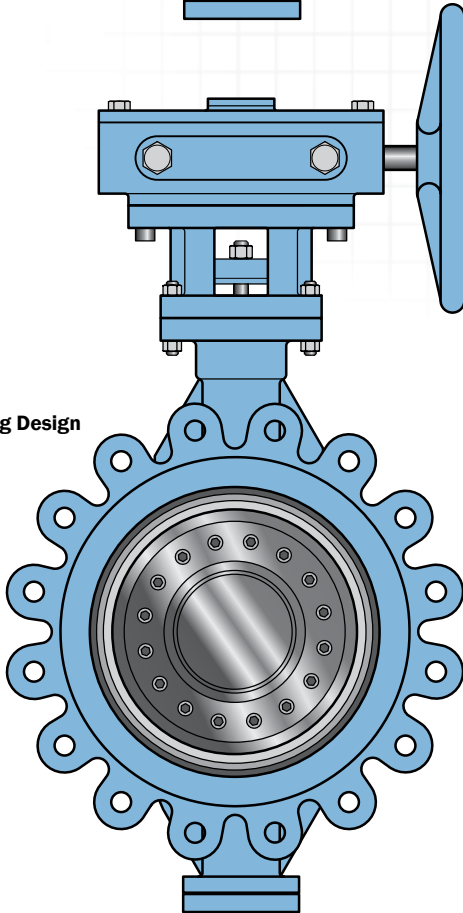

COMPONENT	WCB/WCB	316/316
Screw	A193 B8M class 1	A193 B8M class 2
Body*	A216 GR WCB	A351 GR. CF8M
Cap	A105	316 SST
Shaft Bearing	316 SST/Nitrited	
Disc	A216 GR WCB	A351 GR. CF8M
Pin	17-4 PH Cond. H1150D	
Bearing Seal	Braided Graphite	
Shaft Bearing	316 SST/Nitrited	
Bearing Seal	Graphite	
Packing Stud	A193 B8M class 1	
Hex Nut	A194 2H	
Yoke	A216 GR WCB	
Key	1045	
Manual Gear	Standard	
Gear Stud	A193 B7	
Hex Nut	A194 2H	
Yoke Stud	A193 B8M class 1	
Hex Nut	A194 8M	
Gland Follower	A351 GR. CF8M	
Packing Gland	A216 GR WCB	A351 GR. CF8M
Shaft Packing	Graphite	
Shaft	17-4 PH Cond. H1150D	
Split Ring	316 SST	
Gasket Ring	316 SST/Graphite	
Seal Ring	316 SST/Graphite	
Retainer	A105	316 SST
Retainer Cap Screw	A193 B8M class 1	

* = Body seat overlay Stellite 6

Branch Locations

Corporate Headquarters
Stafford, Texas
13127 Trinity Dr.
Stafford, TX 77477
Tel: 281.302.4900
Toll Free: 800.231.3505

Houston, Texas
1300 Gazin St.
Houston, TX 77020
Tel: 713.675.8631

Carson, California
1539 Del Amo Blvd.
Carson, CA 90746
Tel: 310.667.8570

East Brunswick, New Jersey
19A Cotters Lane
East Brunswick, NJ 08816
Tel: 732.257.0300

Atlanta, Georgia
3065 Chastain Meadows Pkwy.
Building 200 - Suite 200
Marietta, GA 30066
Tel: 678.278.4000

Chicago, Illinois
1050 North State St. Ste. M3
Chicago, IL
Tel: 281.302.4900

Edmonton, Alberta
9555 - 12th Av SW
Edmonton, AB T6X 0C6 - Canada
Tel: 780.464.3500

Barrie, Ontario
92 Davidson Street
Barrie, ON L4M4Y6 - Canada
Tel: 705.737.4216

Shanghai, China
Suite 702, Jinying Tower A
1518 Minsheng Road
Pudong, Shanghai China 200135
Tel: ++86.21.6104.9569

Bergamo, Italy
Piazza Salvo D'Acquisto, 90
24069 Trescore
Balneario (BG) - Italy
Tel: ++39.035.944914

Melbourne, Australia
8-10 Apoinga St
Dandenong Vic 3175
Tel: ++61.039.7683444

Brisbane, Australia
3/36 Premier Circuit
Warana - Queensland, 4575
Tel: ++07.5445.6599