

Welcome To Our House Gator Series



The TOUGHEST Chopper Pumps on the Market!

- External Blades for Superior Chopping
- Customized to Fit Your Needs
- Mixing and Air Injection Capabilities
- Motor Sizes Up to 49 HP

**- Devouring prison uniforms,
animals, and lift station
debris for over 55 years!**

Landia[®]

Chopping Blades - The Heart and Soul of the Gator



Exterior Chopping Blades

Chop all debris prior to entering the volute.



EradiGator

- Portable design
- Effortless installation-Just drop it in and start it up!
- Eradicates large debris by chopping it to shreds
- Mixes tank through customized nozzle design
- Reduces grease build-up through mixing
- Eliminates sedimentation through effective mixing





AeriGator

- Eliminates large debris by chopping it to shreds
- Effectively mixes tank through infused air and water
- Reduces grease build-up through mixing
- Eliminates sedimentation through effective mixing
- Reduces or eliminates odors and corrosive H_2S gas through infused air





ScumiGator

- Eliminates large debris by chopping it to shreds
- Mixes tank through customized nozzle design
- Reduces grease build-up through mixing
- Eliminates sedimentation through effective mixing

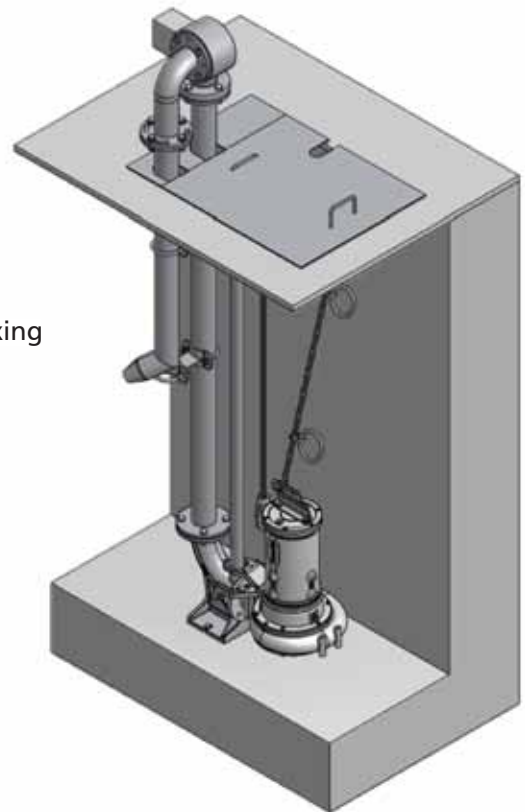



ConvictiGator

- Eliminates large debris by chopping it to shreds
- Macerating auger feeds hungry choppers
- Reduces grease build-up through mixing
- Eliminates sedimentation through effective mixing





Landia EradiGator handles the problematic trash found in prison wastewater systems.

Wes Cullin, Facilities Maintenance Superintendent at Crittenden County Detention Center, said:

»We have not had one single problem with the Landia Pumps. They have been operating great!«

Landia's Heavy-Duty Chopper Pumps are Recommended for a Wide Range of Applications

Thousands of Landia chopper pumps are in operation worldwide, pumping various types of severe mediums where traditional pumps have experienced continuous problems, such as clogging, pump failure, etc.

- Domestic wastewater containing food, paper, rags, fat, etc.
- Abattoir wastewater containing bones, intestines, feathers, hair, fat, etc.
- Waste oil from industrial manufacturing facilities, repair shops, etc.
- Fish and fish by-products
- Paper pulp and paper waste
- Sludge, organic waste, slurry and straw at biogas plants
- Cooling water containing hard solids

- Don't forget to feed the Gator!



CK19A.C15-011009

LANDIA A/S
DENMARK
ISO 9001

Landia[®]

Headquarters:
Landia A/S
Industrivej 2
DK-6940 Lem St.
Tel.: +45 97 34 12 44
Fax: +45 97 34 16 98
e-mail: info@landia.dk
www.landia.dk

Landia Inc.
111 Triangle Trade Drive
Cary, NC 27513
Phone: 919 466 0603
Fax: 919 460 1666
E-mail: info@landiainc.com
www.landiainc.com