

Short Nozzle Insertion Clearance (Inches)

		Dual	Triple
Free Hand	Best	3	3
	Worst	3	3
Fixed Center Line	Best	3-7/8	3-7/8
	Worst	3-7/8	3-7/8

Long Nozzle Insertion Clearance (Inches)

		Dual	Triple
Free Hand	Best	3	3-1/4
	Worst	3-7/16	3-3/16
Fixed Center Line	Best	3-7/8	4
	Worst	4-1/4	4-1/4

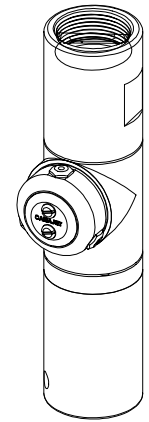
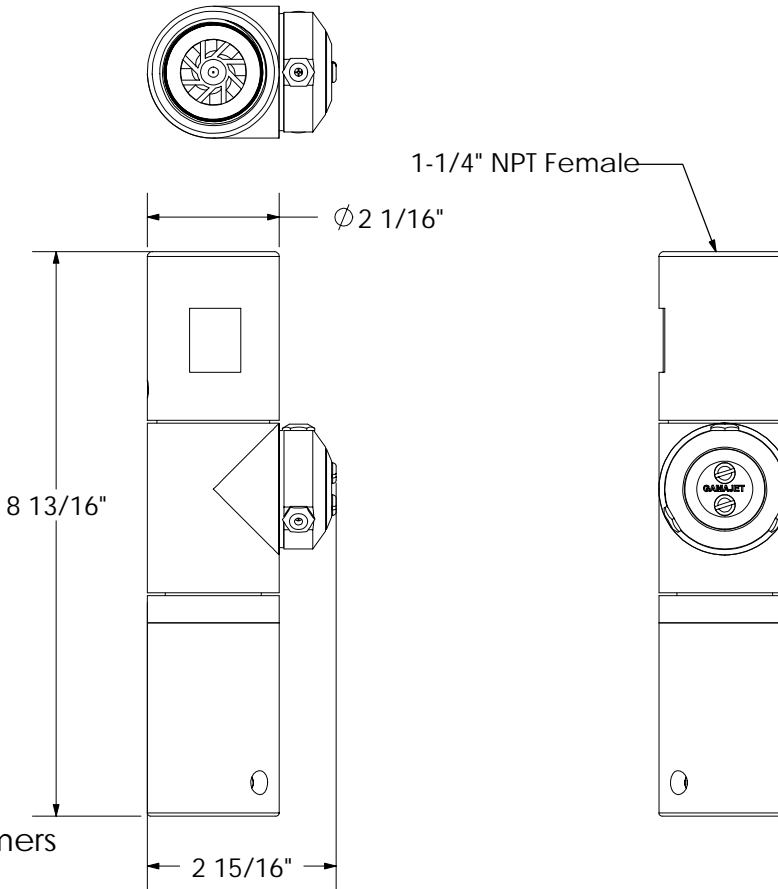

Notes:

- 316 SS, 18-8 Fasteners, Plastics, and Elastomers
- Weight: 7 lbs.
- Dual and Triple (Shown) Nozzle Available
- Short (Shown) and Long Nozzles Available
- Nozzle Sizes: range from .125" to .250"
- Flow Range: 10 to 40 GPM
- Pressure Range: 50 to 1200+ PSIG
- Min Full Wash Cycle: 8 minutes

THIS DRAWING IS THE PROPERTY OF GAMAJET CLEANING SYSTEMS, INC. REPRODUCTIONS AND USE OTHER THAN BORROWER'S AGREEMENT IS PROHIBITED. THIS DOCUMENT SHALL NOT BE LENT OR DISPOSED OF DIRECTLY OR INDIRECTLY NOR USED FOR ANY PURPOSE OTHER THAN THAT WHICH IS SPECIFICALLY FURNISHED.

DRAWN	DATE	Rev.	Description
BFG	06/28/00	1	New Drawing

UNLESS OTHERWISE SPECIFIED * DIMENSIONS ARE IN INCHES * [] DIMENSIONS ARE mm * DEBURR ALL SURFACES * FILLET RAD.: 0.015 * TOLERANCES: XX ±0.01 XXX ±0.005 ANGLE ±0.5°		GAMAJET CLEANING SYSTEMS, INC. 2485 Yellow Springs Road Building One Malvern, PA 19355	
MATERIAL: Material		TITLE Three View Marketing	
FINISH (UNLESS OTHERWISE SPECIFIED): ??? Ra		EQUIPMENT Gamajet V	
SCALE: Full		DWG. NO. ---	SHEET 1 OF 1

GAMAJET V- DIRECTIONAL - THREE VIEW MARKETING

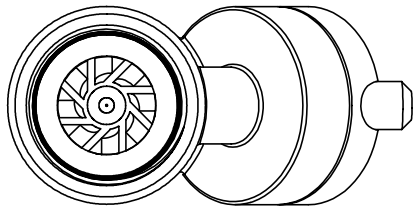

- Notes:
- 316 SS, 18-8 SS Fasteners, Plastics, and Elastomers
 - Weight : 8.5 lbs
 - Dual (Shown) and Triple Nozzle Available
 - Nozzle Sizes : 0.125" to 0.250" Long
 - Flow Range: 10 to 40 GPM
 - Flow Range : 50 to 1200 PSIG
 - Min. Full Wash Cycle: 8 Minutes

INSERTION CLEARANCES (INCHES)	
FREE HAND	4 - 3/8"
FIXED CENTER LINE	6 - 1/2"

