

Inlet:
 - 2" NPT Female/ 2-1/2" Camlock Adapter (Standard)
 - 2" NPT Female/ 2-1/2" NST (Optional)

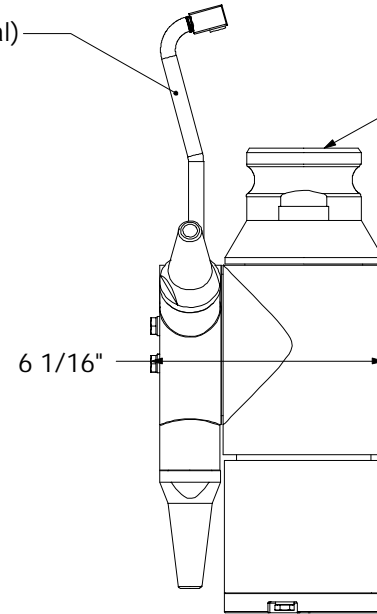
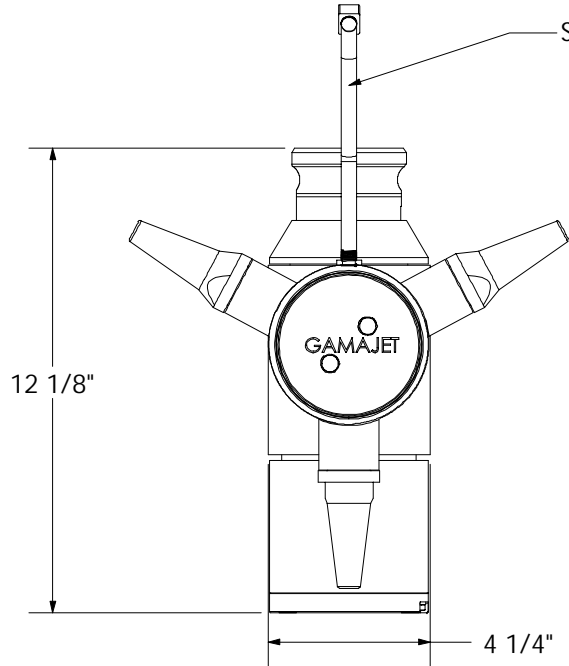

Notes:

- 316 SS, 18-8 Fasteners, Plastics, and Elastomers
- Weight: 28 lbs (Dual), 29 lbs (Triple, Shown)
- Nozzle Sizes: range from 1/4" to 5/8"
- Flow Range: 30 to 300+ (us)gpm
- Pressure Range: 20 to 500 psig
- Min. Full Wash Cycle: 6 minutes
- Clearances:
 Pin Drive - 12.7" Dual, 11.5" Triple
 Clutch Drive - 6.7" Dual, 9.6" Triple

THIS DRAWING IS THE PROPERTY OF GAMAJET CLEANING SYSTEMS, INC. REPRODUCTIONS AND USE OTHER THAN BORROWER'S AGREEMENT IS PROHIBITED. THIS DOCUMENT SHALL NOT BE LENT OR DISPOSED OF DIRECTLY OR INDIRECTLY NOR USED FOR ANY PURPOSE OTHER THAN THAT WHICH IS SPECIFICALLY FURNISHED.

| DRAWN | DATE | Rev. | Description |
|-------|----------|------|-------------|
| BFG | 10/02/00 | 1 | New Drawing |
| | | | |
| | | | |
| | | | |

| | | | |
|--|--|--|--------------|
| UNLESS OTHERWISE SPECIFIED | | GAMAJET CLEANING SYSTEMS, INC. 2485 Yellow Springs Road Building One Malvern, PA 19355 | |
| * DIMENSIONS ARE IN INCHES * [] DIMENSIONS ARE mm * DEBURR ALL SURFACES * FILLET RAD.: 0.015 * TOLERANCES: XX ±0.01 XXX ±0.005 ANGLE ±0.5° | | | |
| MATERIAL: See Notes | | TITLE Three View Marketing Drawing | |
| FINISH (UNLESS OTHERWISE SPECIFIED): ??? Ra | | EQUIPMENT Gamajet IV | |
| SCALE: Full | | DWG. NO. --- | SHEET 1 OF 1 |