

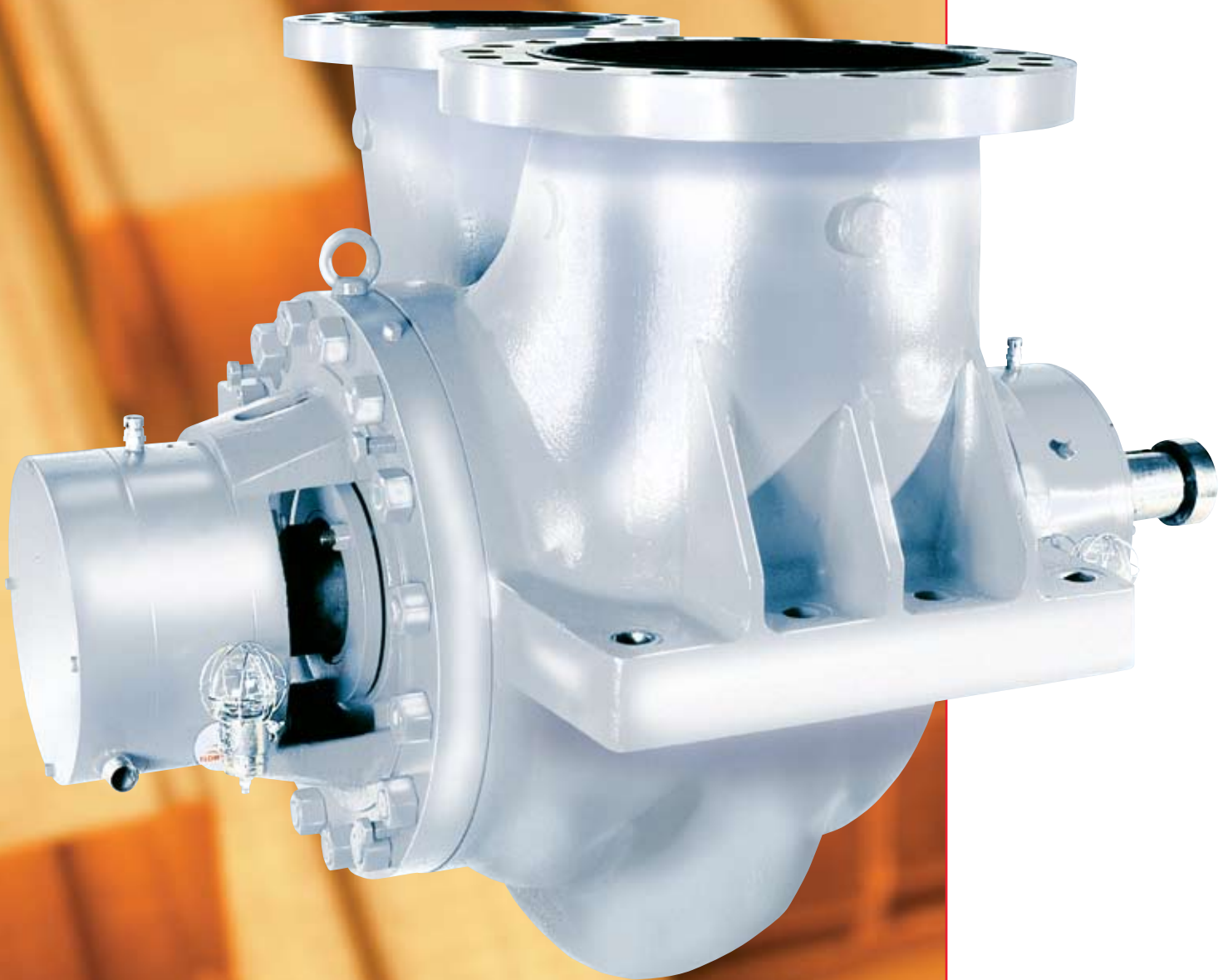

Pump Division

## ***HDX***

***API 610 (BB2)  
Radially Split,  
Double Suction  
Process Pump***



## Pump Supplier To The World

*Flowserve is the driving force in the global industrial pump marketplace. No other pump company in the world has the depth or breadth of expertise in the successful application of pre-engineered, engineered and special purpose pumps and systems.*

### Pumping Solutions

Flowserve is providing pumping solutions which permit customers to continuously improve productivity, profitability and pumping system reliability.

### Market Focused Customer Support

Product and industry specialists develop effective proposals and solutions directed toward market and customer preferences. They offer technical advice and assistance throughout each stage of the product life cycle, beginning with the inquiry.



### Dynamic Technologies

Flowserve is without peer in the development and application of pump technology, including:

- Hydraulic engineering
- Mechanical design
- Materials science
- Intelligent pumping
- Manufacturing technology

### Broad Product Lines

Flowserve offers a wide range of complementary pump types, from pre-engineered process pumps, to highly engineered and special purpose pumps and systems. Pumps are built to recognized global standards and customer specifications.

Pump designs include:

- Single stage process
- Between bearing single stage
- Between bearing multistage
- Vertical
- Submersible motor
- Rotary
- Reciprocating
- Nuclear
- Specialty

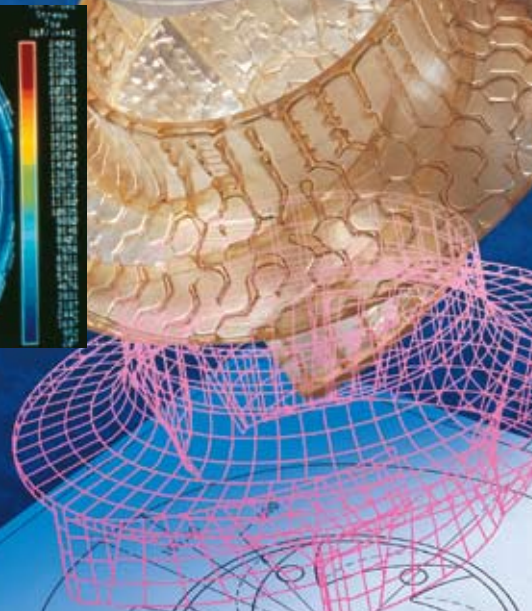
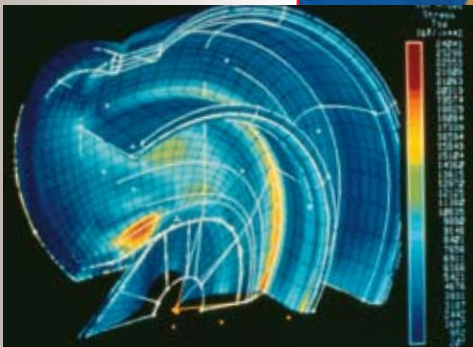

**HDX**  
**API 610 (BB2)**  
**Radially Split,**  
**Double Suction**  
**Process Pump**

**Heavy-Duty Between Bearings Pumping Leader**

The HDX line of pumps complements flow and pressure requirements between overhung and multistage process pump lines for high temperature applications.

These top suction, top discharge, between bearing, centerline mounted pumps are fully compliant with API 610, type BB2. They incorporate all of the design requirements

specified by the demanding hydrocarbon-processing industry, as well as power and specialty users. These include:

- Nozzle-loading capability specified by API 610
- Mechanical seal chambers in accordance with API 682
- Centerline-mounted casing
- Bearing options
- Pressure casing and wear part material options
- Control and monitoring systems
- Low NPSH capabilities

**Broad Application**

- Petroleum refining, production and distribution
- Petrochemical and heavy-duty chemical processing
- Gas industry services
- Boiler-feed booster and other high temperature services
- Water and general industrial

**Complementary Pump Designs**

HDX pumps may be used with other Flowserve models of API design. These include:

- Single-stage overhung pumps
- Multistage between bearings pumps
- Vertical, double casing pumps
- Specialty pumps

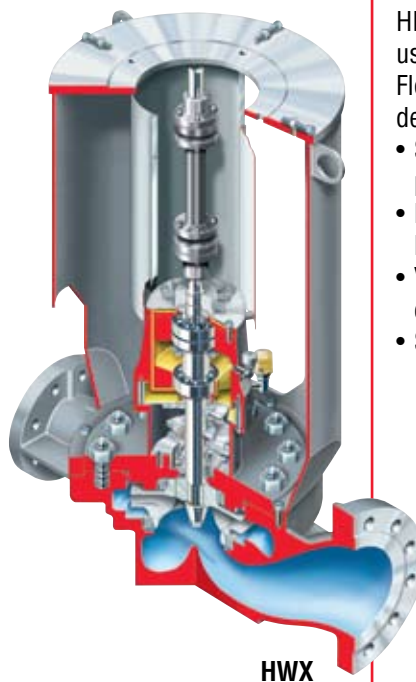

HWX

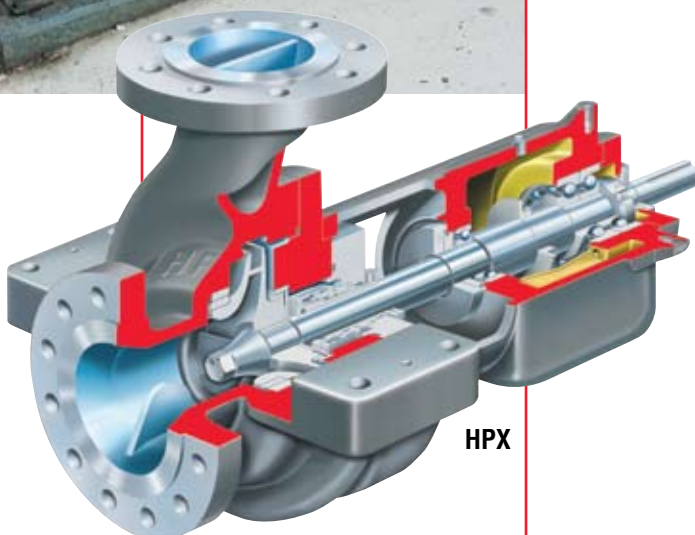

HPX



VPC

**HDX**  
**API 610 (BB2)**  
**Radially Split,**  
**Double Suction**  
**Process Pump**

The Flowserve HDX pump meets or exceeds the vigorous requirements of API 610, latest edition. It is engineered and built for reliable, safe performance at the elevated temperatures and pressures experienced in refining and power applications.

Further, the HDX represents the most comprehensive range of hydraulic coverage available to the industry, thereby permitting precise selection for best operating efficiency.

**Dual-Volute Centerline Supported Casing,** combined with a stiff shaft design, ensures:

- Full compliance with API 610 specified nozzle loads
- Full compliance with API 610 vibration and shaft run-out requirements

**Double Casing Covers** offer easy maintenance. Gasketing is metal to metal fit, fully confined and controlled compression, to ensure proper sealing and alignment when handling hot hydrocarbon liquids

**Double Suction Impeller** minimizes thrust problems, reduces NPSH requirements and allows mechanical seals to operate at equal and low pressure

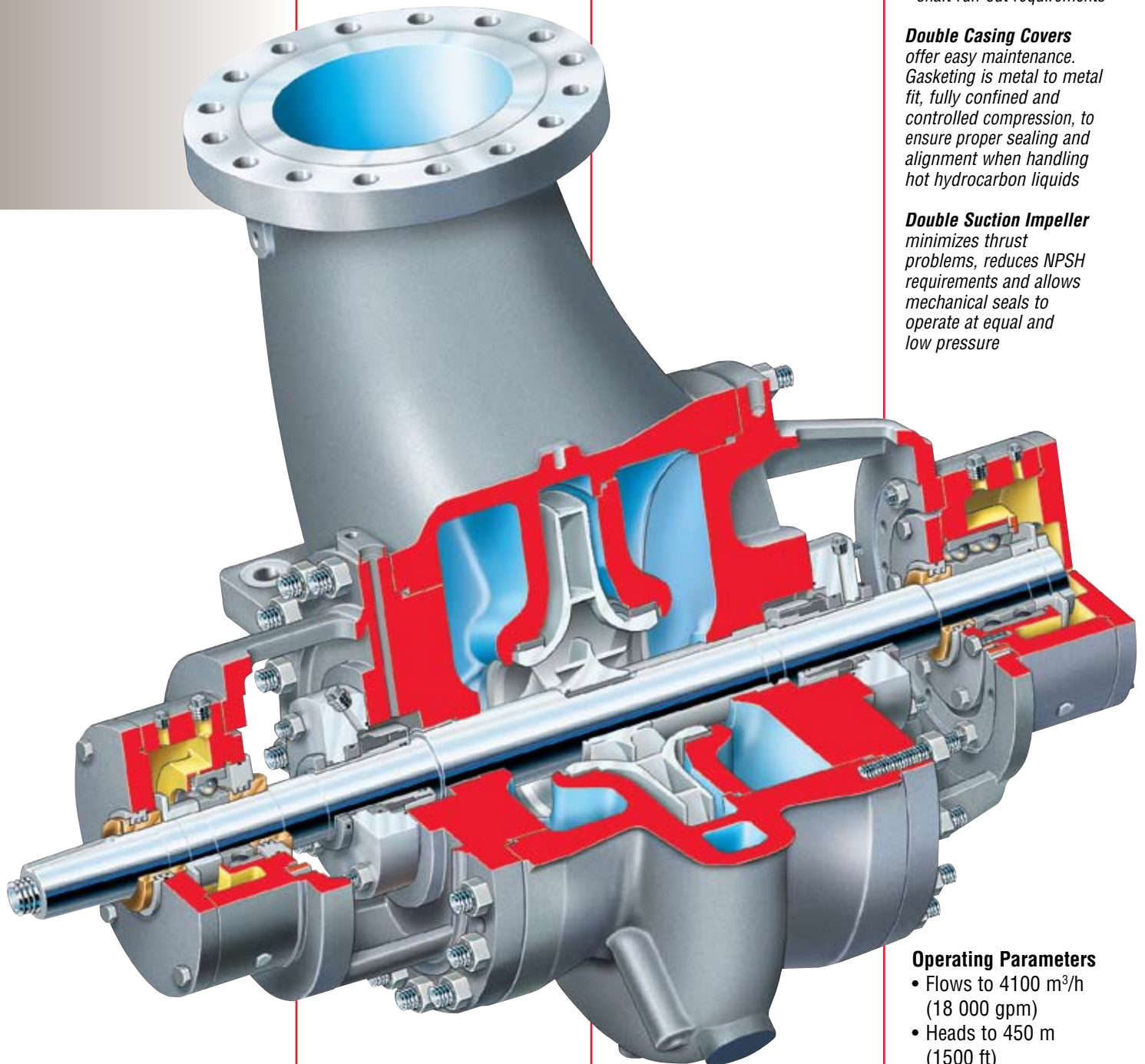

**Operating Parameters**

- Flows to 4100 m<sup>3</sup>/h (18 000 gpm)
- Heads to 450 m (1500 ft)
- Temperatures to 450°C (850°F)
- Pressures to 100 bar (1500 psi)

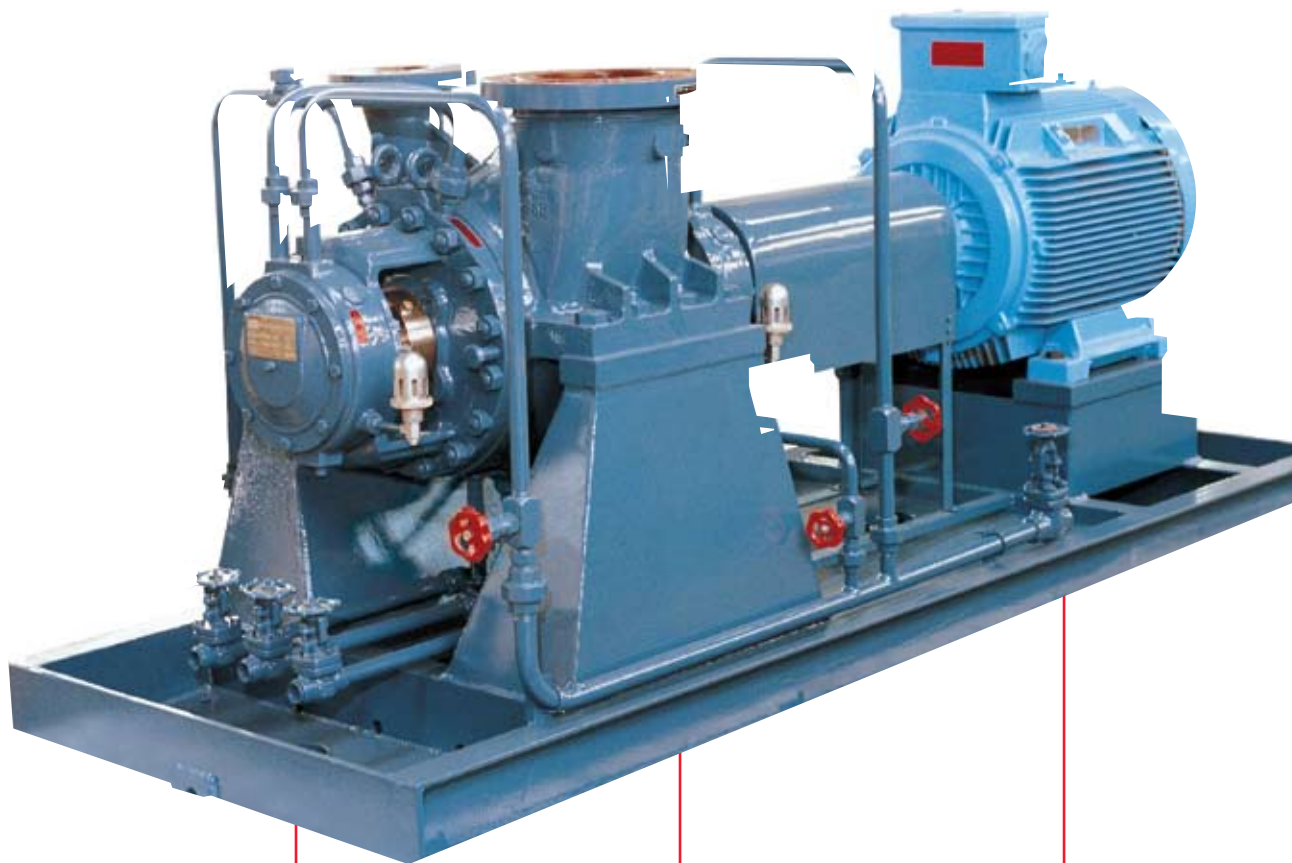

**Dynamically Balanced Rotor** ensures smooth operation for longer mechanical seal and bearing life

**Rotating Elements** include large diameter shafts and short bearing spans to increase shaft stiffness. Final two plane dynamic balancing and TIR verifications are conducted on assembled rotors to assure optimum mechanical performance throughout the operating range

**Self-Venting Casing** eliminates the need for a vent valve and associated piping

**360° Support Bearing Housings** are made of carbon steel to provide added stiffness and reduced vibration. Shaft mounted fans can be provided for air cooling in lieu of water cooling

**Seal Chambers** to API 682 dimensional criteria allow for installation of cartridge design single, dual unpressurized and dual pressurized mechanical seals to meet the required safety and environmental requirements

**Cartridge Seal Mounting Assures:**

- Ease of maintenance
- Precise seal face setting for maximum seal life

**Standard Radial Bearing** is antifriction single-row Conrad type

**Standard Thrust Bearing** is dual single-row back-to-back mounted angular contact type. Optional bearing arrangements and lubrication systems are available to meet the requirements of any speed or application

**Casing** is supplied with minimum flange ratings of ASME B16.5 Class 300 suction and discharge. Class 600 and 900 are also available to meet the required operating pressures



**Pump Packages** are provided to specifications and include lube oil piping, seal systems, monitoring instruments and drive train mounting. Pumps mounted with engine or turbine drivers and multiple pump modules are also available

**Certified Testing** is performed on each pump prior to shipment

**Casing and Internal Material Combinations** available to meet service requirements include carbon steel, 12% chrome, austenitic stainless steels, Monel® and duplex

© Monel is a registered trademark of International Nickel Co

**Options and Technical Data**

**Bearing Options**

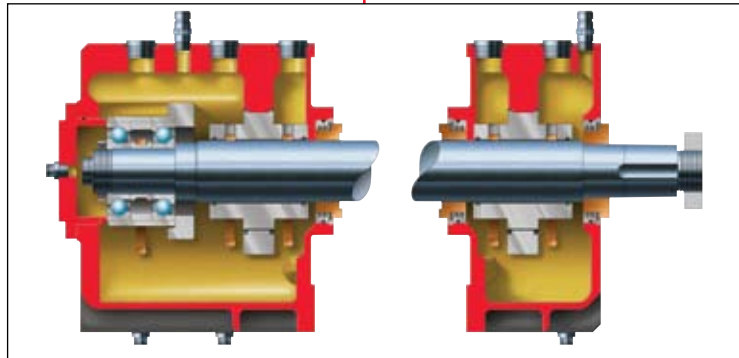

**Sleeve Radial and Ball Thrust**

- Applied to energy density (=power x rated speed) ratings of 4.0 million (=kW x rpm) or 5.4 million (=hp x rpm) maximum

- Standard for applications where thrust bearing speed and life for rolling element bearings are within API 610 limits

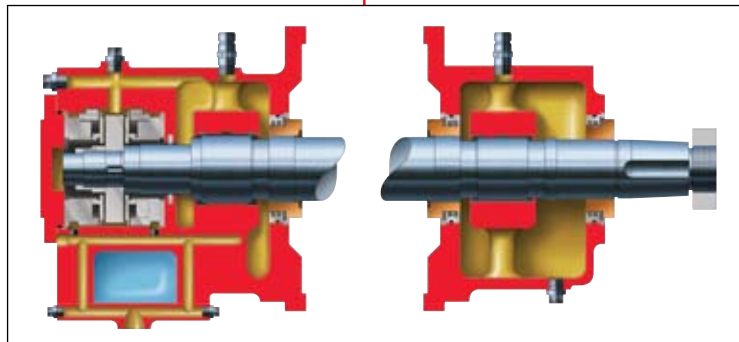

**Sleeve Radial and Tilting Pad Thrust**

- Applied when energy density ratings and bearing speed or life is beyond the limits for rolling element bearings as defined by API 610

- Tilting pad thrust bearings normally require an external forced feed lubrication system. Pump shaft driven or separate lube pumps available

**Shaft Options**

- Hydraulic-fitted coupling
- Double extended

**Baseplate Options**

- Welded steel with drain rim
- Sub-base under pump only
- Skid type non-grouted
- 3-point design
- Pregrouted design

**Other Options**

- Pure or oil mist lubrication of bearings
- Water or fan cooled bearings
- Coatings for slurry services
- Coke crusher construction



Side-Side Nozzles



In-line Side Nozzles



Fan Cooling

**HDX Range Chart**

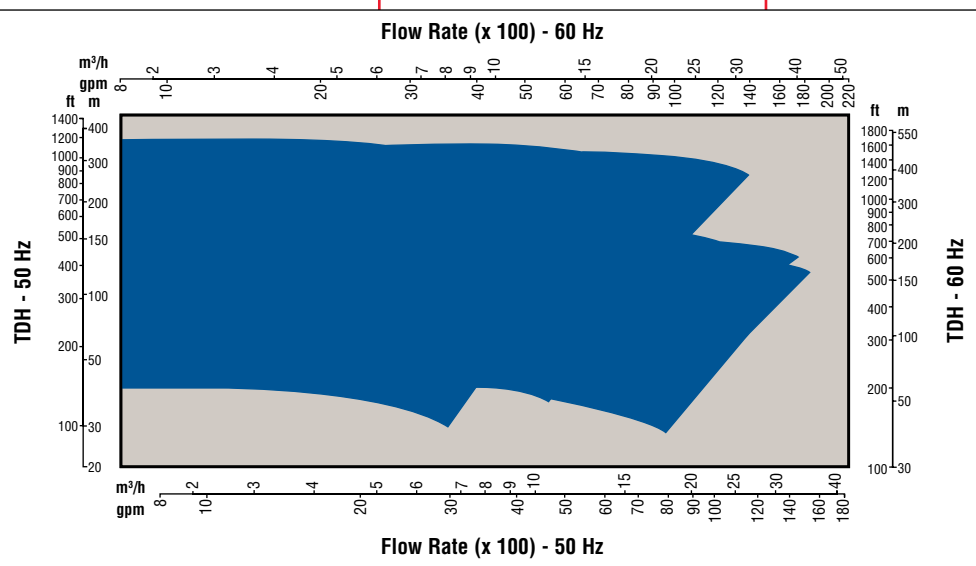

**Global Engineered Services and Support**

- Total Cost Reduction*
- Asset Management*
- Product Life Cycle*
- Performance Re-rates*
- Site Diagnostics*
- Repair Services*
- Energy Management*
- Spare Parts*
- Maintenance Contracts*
- Materials Upgrades*
- Turnkey Services*
- Field Repairs*
- Installation*
- Project Supervision*
- Commissioning*
- Equipment Upgrades*
- Condition Monitoring*
- Systems Analysis*
- Field Machining*

**Service Dedication**

Flowserve Engineered Services is focused on providing customers with uncompromising service and support, where and when needed. Dedicated to delivering the highest quality support, Engineered Services integrates its extensive pump and materials engineering knowledge with creative service solutions. Engineered Services fully understands the business challenges facing customers and is prepared to manage solutions to succeed as a team.

A worldwide network of service and repair centers staffed by highly skilled engineers and technicians is available around the clock, seven days a week to respond to customer queries, to evaluate and troubleshoot problems and to provide reliable solutions.



**Strength of Experience, Commitment to Excellence**

Flowserve has long served industries requiring superior equipment performance and service life.

- Oil and gas production
- Hydrocarbon processing
- Chemical processing
- Water resources
- Power generation
- Nuclear
- Mining and mineral processing
- Pulp and paper
- General industry

Engineered Services is dedicated to maximizing equipment performance and providing reliability-centered maintenance programs for pumps and related equipment, regardless of manufacturer. Using the FlowStar™ asset management software, Engineered Services tracks performance and supports improvement programs using a service life cycle cost business approach. The results are improved reliability and increased profitability.

**Business Partner**

Flowserve partners with customers to respond to the dynamic business conditions that affect them. Flowserve will work with customers to drive efficiency, maximize throughput and control process quality. Whether user needs involve on-site technical assistance or broader project planning with full turnkey responsibility, Flowserve Engineered Services will deliver professional, reliable results.



**Low Frequency Pressure Pulsations**

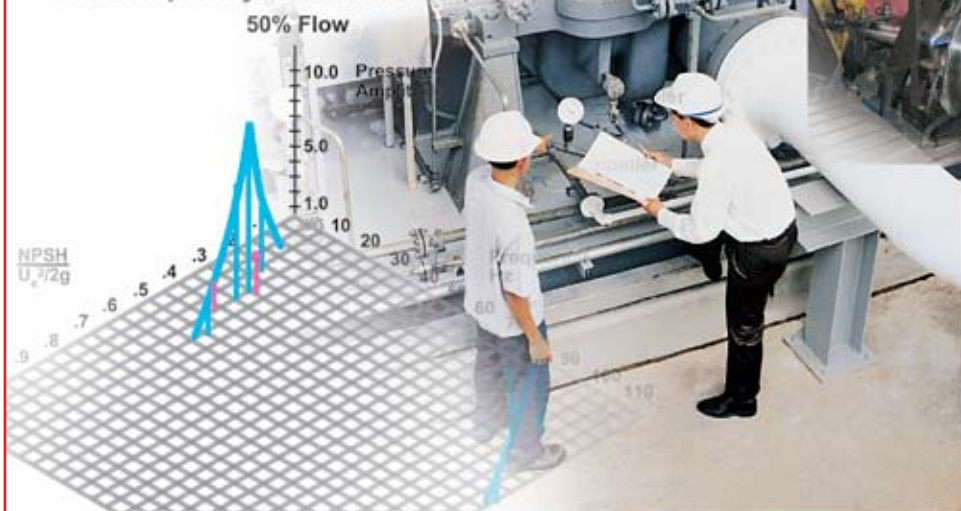

**Flowserve... Supporting Our Customers  
With The World's Leading  
Pump Brands**



**USA and Canada**

Flowserve Corporation  
5215 North O'Connor Blvd.  
Suite 2300  
Irving, Texas 75039-5421 USA  
Telephone: 1 937 890 5839

**Europe, Middle East, Africa**

Flowserve Corporation  
Gebouw Hagepoint  
Westbroek 39-51  
4822 ZX Breda  
Netherlands  
Telephone: 31 76 502 8920



*Your local Flowserve representative:*

**To find your local Flowserve representative  
please use the Sales Support Locator System  
found at [www.flowserve.com](http://www.flowserve.com)**

**Or call toll free: 1 800 728 PUMP (7867)**

**Latin America**

Flowserve Corporation  
Boulevard del Cafetal  
Edificio Ninina, Local 7  
El Cafetal - Caracas  
Venezuela 1061  
Telephone: 58 212 985 3092  
Telefax: 58 212 985 1007

**Asia Pacific**

Flowserve Pte. Ltd.  
10 Tuas Loop  
Singapore 637345  
Telephone: 65 6771 0600  
Telefax: 65 6779 4607