



*Mach 1*TM

H I G H P E R F O R M A N C E
P L U G V A L V E



B r e a k i n g T h e B a r r i e r s



Quality
System
Certificate

Bulletin V-300b

TABLE OF CONTENTS

SECTION	TITLE	PAGE
I	INSTALLATION.....	2
II	OPERATING/MAINTENANCE INSTRUCTIONS FOR MACH 1.....	3
III	VALVE DISASSEMBLY - MACH 1	
	RECOMMENDED PRECAUTIONARY MEASURES.....	4
	DISASSEMBLY STEPS.....	4
IV	PRESSURE CONTAINING FASTENERS.....	5
V	A. VALVE ASSEMBLY 1"-6" MACH 1 WITH PORT SEALS.....	6
	B. VALVE ASSEMBLY 1"-6" MACH 1 WITH SLEEVE.....	9
VI	ASSEMBLY SPECIFICATIONS - FIRESEAL VALVES 1"-6" MACH 1.....	10

SECTION I

INSTALLATION INSTRUCTIONS - FLANGED MACH 1, CLASS 150, 300 AND 600

FLANGED:

Installation of Flowserve flanged valves is best accomplished by locating valves in pipeline flanges, assuring all corrosion and foreign materials are removed from pipe flanges and then center gaskets with the valve flanges. Fasteners or taper pins should be used to align holes and locate gaskets. Fasteners should be tightened to the corresponding valve and fastener size.

**TABLE I-1
Temperature Limitations**

Material Description	Maximum Service Temperature
PFA	525°F (274°C)

SECTION II

OPERATING/MAINTENANCE INSTRUCTIONS FOR MACH 1

Maintenance requirements for Mach 1 valves may vary due to operating conditions of the process. Factors such as operating temperature, pressure, solids content, and frequency of cycling can influence valve performance and maintenance requirements.

Seal wear is compensated by adjusting appropriate parts. For Mach 1 valves, there are three possible leak paths:

1. Top Cap (bonnet)
2. Stem
3. Line (through)

Corresponding adjustments for each leak path are as follows.
NOTE: Refer to Figure II-1 or Figure VI-1 for parts identification

1. Top Cap (bonnet)

Leakage due to thermal or pressure cycling is eliminated by tightening the top cap fasteners (Part 10) in a “criss-cross” pattern to the torque values given in the tables. This adjustment is most effective when the valve is not pressurized. It is important that the top cap fasteners not be tightened excessively and that torque values applied be within industry standard for fasteners.

2. Stem

Leakage due to wear of the diaphragm, and/or wear to the sleeve (primary seal) is eliminated by tightening the adjuster fasteners (Part 11) in 1/4 turn increments. The adjuster fasteners must be tightened evenly for maximum adjustment. The valve should be operated between adjustments to assure that the plug properly seats itself into the sleeve. If leakage persists after repeated adjustments, the sleeve and diaphragm will require replacement as covered in Section V and Section VI.

3. Line (through)

Through leakage due to wear of the primary seal can be eliminated by tightening the adjuster fasteners (Part 11) in 1/4 turn increments. The fasteners must be tightened evenly for maximum adjustment. The valve should be operated during adjustments to prevent excessive operating torque. Should leakage persist after repeated adjustments, the port seals or sleeve will require replacement as covered in Section V and Section VI.

FIGURE II-1
Typical Assembly of Mach 1

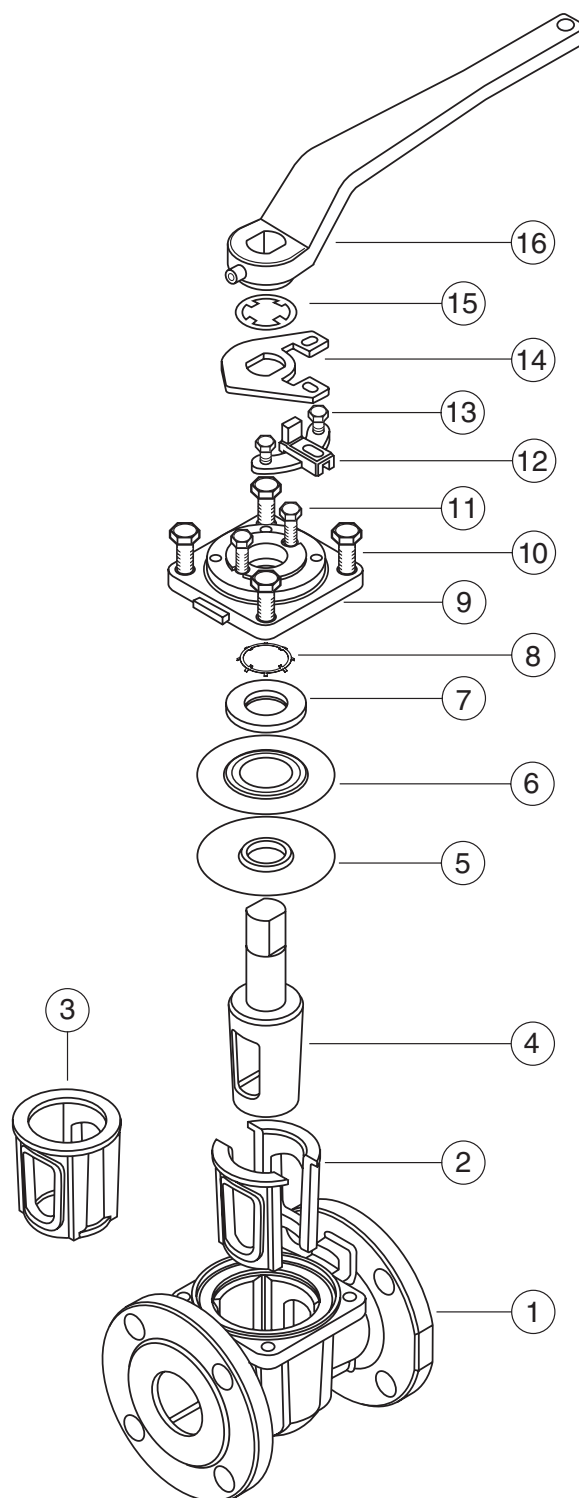

WARNING

To avoid personal injury and prevent damage to equipment, do not operate or repair this valve without observing the following procedures outlined in this manual.

SECTION III

VALVE DISASSEMBLY - MACH 1

RECOMMEND PRECAUTIONARY MEASURES

1. Valves must be relieved of process fluid and pressure prior to disassembly.
2. Personnel performing disassembly must be suitably protected and alert for emission of hazardous process fluid.

DISASSEMBLY STEPS

NOTE: Refer to Figure II-1 or VI-1 for parts identification. If an actuator or gearbox operates the valve, alignment marks should be noted to assure correct orientation when reassembled. This may best be accomplished by making matching marks on the plug stem and operator housing with no burrs made on the plug stem.

1. Remove the wrench (Part 16), if so equipped. Remove the stop collar retainer (Part 15), stop collar (Part 14) and locking stop (Part 12) after marking their orientation.
2. Gradually loosen adjuster fasteners (Part 11) - DO NOT REMOVE.
3. **WARNING: Do not loosen or remove top cap fasteners (Part 10) when removing an operator. Remove the operator by unfastening it from the bracket.**
4. Turn plug (Part 4) in order to raise the plug to vent any material trapped in the valve (see note below).
NOTE: If there is no upward movement of the plug, it will be necessary to devise a method of lifting the plug upward. This may require removal of the valve operator (Step 3). This operation should be undertaken noting the above precautionary measures. Methods of plug removal must include protective measures on plug stem and plug end.
5. Once the plug has lifted, the adjuster fasteners (Part 11) can be completely removed.
6. Gradually loosen but DO NOT REMOVE all of the top cap fasteners (Part 10). Turn the plug until it is loose from the port seal (Part 2) or sleeve (Part 3) and all pressure has been vented. (Again, it may be necessary to use a mechanical means to move the plug upwards.)
7. Remove the top cap fasteners and top cap (Part 9) from the plug stem. Retain the tags for attachment during re-assembly.
8. Remove the plug (Part 4) from the body (Part 1).
9. Remove the grounding spring (Part 8) and thrust gland (Part 7).
10. Remove the metal diaphragm (Part 6) and the PFA diaphragm (Part 5) from the plug stem.
11. Inspect the valve port seals or sleeve for wear or damage, especially scratches near the top, bottom, and port areas. If wear or damage is excessive, the port seals/sleeve should be replaced.
12. Remove port seals or sleeve as follows:
NOTE: Care must be taken not to damage the machined internal body bore.
a. Lift port seals out of body bowl.
b. To remove the sleeve, use a wooden dowel and pry the sleeve upward by engaging the dowel in the sleeve at the top of the port. A sharp blow may be necessary to dislodge the sleeve. Both sides of the sleeve may need to be pried upward for removal. (See Figure III-1)
13. Thoroughly clean all valve parts with an acceptable cleaner.
14. Inspect parts for damage. Look for marred, scratched, or rough sealing surfaces on the valve plug or machined body bore.
NOTE: Reinstallation of damaged or unclean parts will ruin any replacement seals installed into the valve.

FIGURE III-1

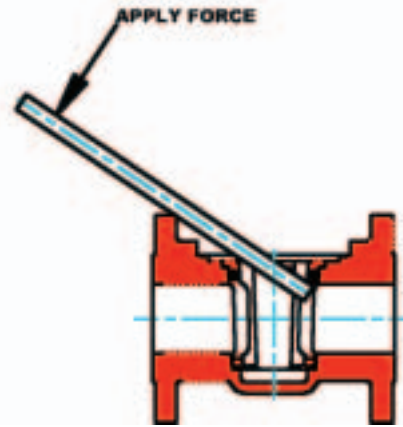

SECTION IV

PRESSURE CONTAINING FASTENERS

MATERIAL SELECTION

Selecting the proper fastener material is the ultimate responsibility of the customer because the supplier does not typically know in what service the valves will be used or what elements may be present in the environment. Flowserve normally supplies B7 (carbon steel) for ductile cast iron and carbon steel valves. For stainless steel and high alloy valves, B8, Class 2B (stainless steel) fasteners are supplied as standard. All fasteners used must have a minimum yield strength of 65,000 PSI, a minimum elongation of 25% and be compatible with the process fluid. Determining compatibility to the process fluid goes beyond a material being resistant to general corrosion because the more important consideration is a material's resistance to stress corrosion cracking. Depending on the service, it may make sense to use B7 fasteners on high alloy valves. One such service would be marine environments because of stainless steel's susceptibility to stress corrosion cracking in chloride environments. Another key aspect of fasteners is frequent visual inspection. Because of the common practice of using steel fasteners rather than stainless steel to avoid chloride stress corrosion cracking, visual inspection is recommended to monitor the general corrosion of these fasteners. If jacketing or insulation is used on a valve, it must be periodically removed

for visual inspection of the fasteners. If you wish assistance in determining the proper fasteners to use, please refer to the attached chart.

DESIGN & TYPE

Flowserve's valve design standards adopt ASME B18.2.1 (1996, Addenda 1999) as the standard for fastener type and design. This national standards requires that finished hex 'head' cap screws be used when the head of the fastener is turned. A finished hex 'head' cap screw and a heavy hex cap screw have a bearing surface under the head to minimize frictional resistance during tightening. They also comply to qualified body diameters and fully formed head dimensions. Cookeville Valve Operation's policy is to use finished hex 'head' and heavy hex 'head' cap screws for all pressure retaining fasteners. This includes top caps, packing adjusters, plug adjusters, bottom caps, body halves or other pressure retaining components. Compliance is made with ANSI B18.2.2 (1987, reaffirmed 1993), Square and Hex Nuts, when studs and heavy hex nuts are required. Additional information on these items may be obtained from the Flowserve Corporation, Cookeville Valve Operation, Cookeville, Tennessee.

**TABLE I
CAP SCREWS - STUDS**

HHCS - Finished Heavy Hex Head Cap Screw	Alloy identification stamp required on each piece.
HCS - Finished Hex Head Cap Screw	Certification required.
STUD - Stud	Alloy Specification (40 KSI Minimum Yield Strength, 12% Minimum Elongation)
Dimensions per ASME B18.2.1	
B9 -	Stainless Steel per ASTM A193, Class 2B, Grade B8 (AISI type 304)
B16	Stainless Steel per ASTM A193, 100% hardness tested
B7 -	Chromium - Molybdenum Alloy Steel per ASTM A193, Grade B7
B7M -	Chromium - Molybdenum Alloy Steel per ASTM A193, Grade B7M, 100% hardness tested
B7MT -	Chromium - Molybdenum Alloy Steel per ASTM A193, Grade B7M, 100% hardness tested, Teflon® coated, Dupont SP11C, Type B - Color blue or green
B8M -	316 Stainless Steel per ASTM A193, Grade B8M, Class 1, 40 KSI Min. Yield Strength, 12% Min. El.
B8C2 -	304 Stainless Steel per ASTM A193, Grade B8, Class 2
C20 -	Carpenter C20, CB-3 (UNS N08020), ASTM B473, 40 KSI Min. Yield Strength, 12% Min. El
HC -	Hastelloy C276 (UNS N10276), ASTM B574
I625 -	Inconel 625 (UNS N006625), ASTM B446
I825	Incoloy 825 (UNS N08825), ASTM B425, 40 KSI Min. Yield Strength, 12% Min. El.
IN -	Inconel 600 (UNS N0660), ASTM B166, 40 KSI Min. Yield Strength, 12% Min. El.
M -	Monel (UNS N04400), ASTM B164, Class A or B, 40 KSI Min. Yield Strength, 12% Min. El.
HB -	Hastelloy B (UNS 10665), ASTM B335
I718 -	Incoloy 718, AMS 5595B
MKH -	Monel K-500, Cold drawn and aged hardened, QQN-286 and ASTM F468
L7 -	Chromium-Molybdenum Alloy Steel per ASTM A320, Grade L7
L7M -	Chromium-Molybdenum Alloy Steel per ASTM A320, Grade L7M, 100% hardness tested
L7T -	Chromium-Molybdenum Alloy Steel per ASTM A320, Grade L7, Teflon® coated, Dupont SP11C, Type B - Color blue or green
L7MT -	Chromium-Molybdenum Alloy Steel per ASTM A320, Grade L7M, 100% hardness tested, Teflon® coated, Dupont SP11C, Type B - Color blue or green
N -	Nickel per ASTM B160 (UNS N0220), 40 KSI Min. Yield Strength, 12% Min. El.
B7YC -	Chromium-Molybdenum Alloy Steel per A193, Grade B7, Yellow Zinc Dichromate Plated

SECTION IV

**TABLE II
NUTS**

HN - Finished Heavy Hex Nut XN - Finished Hex Nut HXN - Regular Heavy Hex Nut Dimension per ANSI B18.2.2 Alloy identification stamp is required on each piece. Certification required.	
8 -	304 Stainless Steel per ASTM A194, Grade 8
8M -	316 Stainless Steel per ASTM A194, Grade 8M
2H -	ASTM A194, Grade 2H
2HM -	ASTM A194, Grade 2HM
7M -	ASTM A194, Grade 7M, 100% hardness tested
7MT -	ASTM A194, Grade 7M, 100% hardness tested, Teflon® coated, Dupont SP11C, Type B - Color blue or green
M -	Monel (UNS N04400), ASTM B164, Class A or B, QQN-281, Class B
HB -	Hastelloy B (UNS 10665), ASTM B335
HC -	Hastelloy C276 (UNS N10276), ASTM B574
I625 -	Inconel 625 (UNS N06625), ASTM B446
I718 -	Incoloy 718, AMS 5596B
I825	Incoloy 825 (UNS N08825), ASTM B425
L7 -	Chromium-Molybdenum Alloy Steel per ASTM A194, Grade 7
L7M -	Chromium-Molybdenum Alloy Steel per ASTM A194, Grade 7M, 235 BHN Max, ASTM A320, Section 9
MKH -	Monel K-500, Cold drawn and aged hardened, QQN-286 and ASTM F467
8F -	303 Stainless Steel per ASTM A194, Grade 8F
2HYC -	ASTM A194, Grade 2H, Yellow Zinc Dichromate Plated

SECTION V

A. VALVE ASSEMBLY 1"-6" MACH 1 WITH PORT SEALS

NOTE: Part number reference is shown in Figure II-1.

1. Mount body (Part 1) on arbor press or table vise holding one flange.
2. Place port seals (Part 2) in position in body. Align port seal ports with body ports. (See Figure V-A1)

FIGURE V-A1



3. Place the plug (Part 4) into the port seals in the closed position.
4. Push the plug (still in the closed position) downward, using the arbor press or other suitable means, until the top of the plug taper is 1/16" above the top port seal surface. Allow the plug to remain in this position for the time listed in Table V-A-I, Port Seal Sizing Times.

**TABLE V-A-I
PORT SEAL SIZING TIMES**

VALVE SIZES	1" - 3"	4" - 6"
TIME (min)	5	8

5. Remove the plug.
6. Assemble the PFA diaphragm (Part 5) over the plug stem (Part 4) with the aid of a diaphragm guide, Part series BY77543A (Figure V-A2). The plug stem and diaphragm guide should be checked for nicks before installing the diaphragm. Nicks on these surfaces could result in scratches on the lip of the diaphragm and must be removed by polishing.

SECTION V

FIGURE V-A2

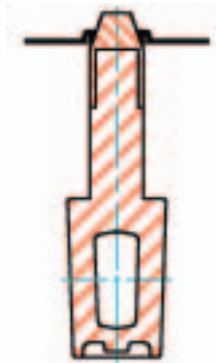

7. Place the metal diaphragm (Part 6) over the plug stem with the raised center section up.
8. Place the thrust gland (Part 7) over the plug stem.
9. Apply a thin film of lubricant to the plug and place the assembled plug (complete with PFA diaphragm, metal diaphragm and thrust gland), in the open position into the body. (Figure V-A3).

FIGURE V-A3

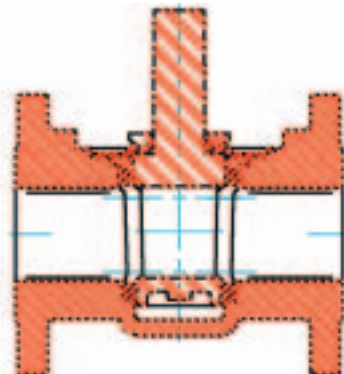

10. Lay the top cap (Part 9) upside down (the bonnet gasket flange upward). Hold the grounding spring (Part 8) so the tabs on the spring ID point downward. Insert the grounding spring into the top cap and push the grounding spring to the bottom of the center cavity in the top cap. (Figure V-A4).

FIGURE V-A4

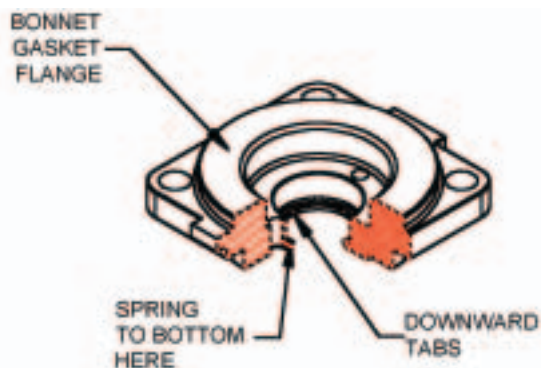

11. Turn the top cap to the right side up position and place the

top cap (with grounding spring in place) over the plug stem. Orient the top cap anti-rotation lugs with the anti-rotation lugs on the body (Figure V-A5).

FIGURE V-A5

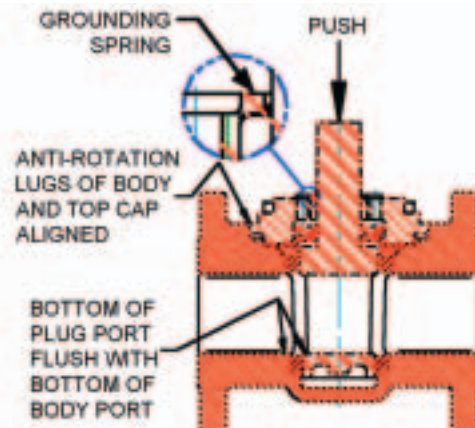

12. Coat the top cap fastener threads (Part 10) with Loctite® 242. Replace the tags removed in step 7 of Section III, *Valve Disassembly*. Install the top cap fasteners in the top cap.
13. Use an arbor press to push the top of the plug downward until **the bottom of the plug port aligns with the bottom of the body port**.
14. Maintain the top cap position relative to the body anti-rotation lugs (Figure V-A5), and using all top cap fasteners (Part 10), tighten evenly in a cross-cross method until the top cap bottoms on the body counterbore. (Figure V-A5). Tighten top cap fasteners to the value per valve size and pressure class as listed in Tables V-A-II, V-A-III and V-A-IV.
15. Remove the valve from the arbor press. Operate the plug several times. Torque will be high, but will reduce and the plug will turn freely.
16. Install adjuster fasteners (Part 11) (Figure V-A6) and hand tighten evenly to the values listed in Table V-A-V or until the bottom of the plug port is 1/16" to 1/8" above the bottom of the body port.

FIGURE V-A6

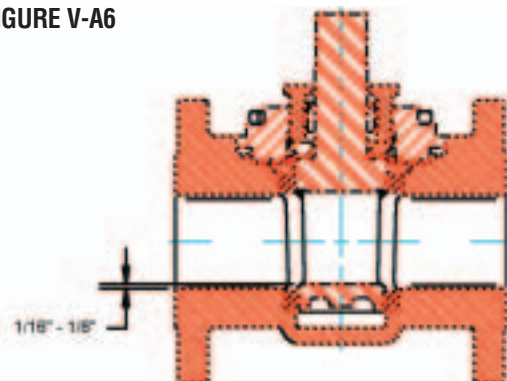

SECTION V

17. Place the locking stop (Part 12) on the top cap as shown in Figure V-A7 and tighten the locking stop fasteners (Part 13) to a reasonable torque. Check their orientation based on the location marks made during disassembly (Section III, step 1).

FIGURE V-A7

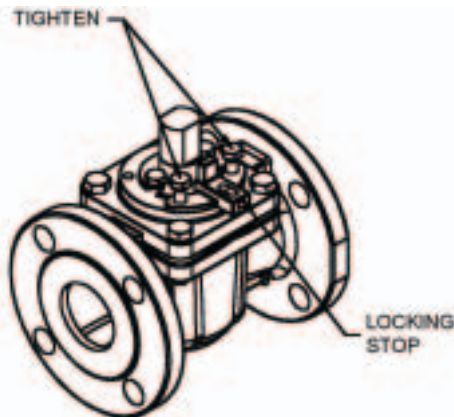

18. Place the stop collar (Part 14) and retainer (Part 15) on the plug stem as shown in Figure V-A8. The stop collar should point in the direction of the flow. Check the orientation based on the location marks made during disassembly (Section III, step 1).

FIGURE V-A8

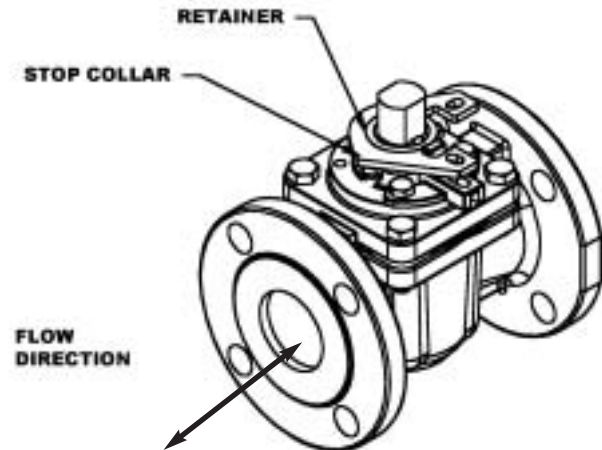

19. The valve should turn clockwise to close. The valve is now ready for test and use.
20. LEAK TESTING: Anytime a valve has been modified in any manner, including fastener changes, it must be re-tested. Normal testing, using gas, should be at 80 PSI for Class 150 through Class 600. Refer to API or MSS for test procedures complying with these specifications.

TABLE V-A-II

*Apply Loctite® 242 to fastener threads, top cap only.

TORQUE REQUIRED ON TOP CAP FASTENERS OF CLASS 150 MACH 1 VALVES

VALVE SIZE	1"	1.5"	2"	3"	4"	6"
MAX. TORQUE (ft-lbs)	10	10	15	28	40	80

TABLE V-A-III

*Apply Loctite® 242 to fastener threads, top cap only.

TORQUE REQUIRED ON TOP CAP FASTENERS OF CLASS 300 MACH 1 VALVES

VALVE SIZE	1"	1.5"	2"	3"	4"	6"
MAX. TORQUE (ft-lbs)	12	12	22	35	62	115

TABLE V-A-IV

*Apply Loctite® 242 to fastener threads, top cap only.

TORQUE REQUIRED ON TOP CAP FASTENERS OF CLASS 600 MACH 1 VALVES

VALVE SIZE	1"	1.5"	2"	3"	4"	6"
MAX. TORQUE (ft-lbs)	14	20	35	45	42	70

TABLE V-A-V

TORQUE ON PLUG ADJUSTER OF MACH 1 VALVES, 150#, 300# AND 600#

VALVE SIZE	1"	1.5"	2"	3"	4"	6"
MAX. TORQUE (in-lbs)	35	35	35	50	75	150

SECTION V

B. VALVE ASSEMBLY 1"-6" MACH 1 WITH SLEEVE

1. Mount body (Part 1) on arbor press or table vise holding one flange.
2. Place the sleeve (Part 3) into the bowl of the body.
WARNING: Sleeve port must be aligned with body port. (See Figure V-B1)

FIGURE V-B1

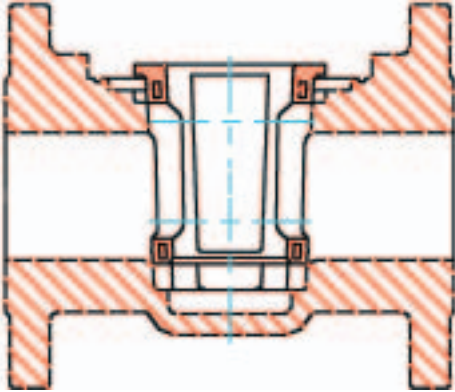

3. Apply a thin film of lubricant on the plug (Part 4).
4. Place the plug in the closed position into the sleeve which is in the body. (See Figure V-B2)

FIGURE V-B2

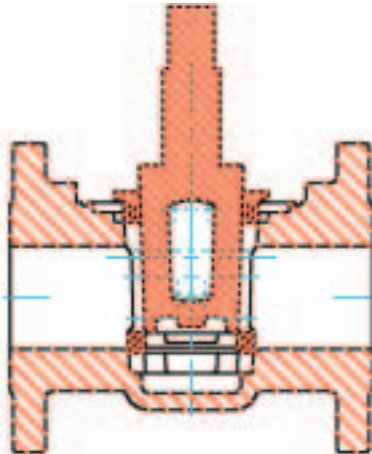

5. Position the top cap (Part 9) over the plug with the anti-rotation lugs aligned with the body lugs, making sure the top cap is free to move downward (Figure V-B3). Using all top cap fasteners (Part 10), tighten evenly in a cross-cross method until the top cap bottoms on the body counterbore.

FIGURE V-B3

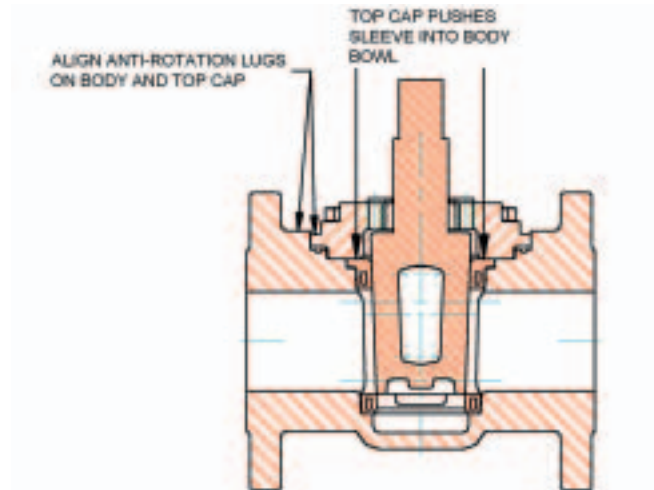

6. Check that the top seal of the sleeve is seated into the body counterbore. (See Figure V-B4) Remove the top cap fasteners and top cap.

FIGURE V-B4

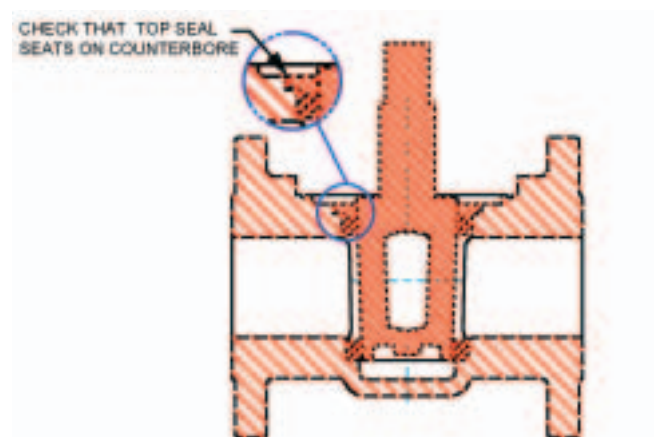

7. Push the plug downward, while still in the closed position, until the top of the plug taper is 1/16" above the top of the sleeve surface. Allow the plug to remain in this position for the time listed in Table V-B-I.

TABLE V-B-I
SLEEVE SIZING TIMES

VALVE SIZES	1" - 3"	4" - 6"
TIME (min)	5	8

8. Remove the plug.
9. Continue with assembly as in V-A, *Valve Assembly of 1"-6" MACH 1 with port seals*, starting at number 6, assembling diaphragms on plug stem.

SECTION VI

ASSEMBLY SPECIFICATIONS - FIRESEAL VALVES 1"-6" MACH 1

NOTE: Part number reference is shown in Figure VI-1.

1. Normal procedures for field replacement of port seals or sleeves are to be followed. Refer to V-A, steps 1-5, and V-B, steps 1-8.
2. The fireseal top seal assembly differs from the standard Mach 1 top seal and is completed per the following instructions.

**FIGURE VI-1
TYPICAL ASSEMBLY OF FIRESEAL MACH 1**

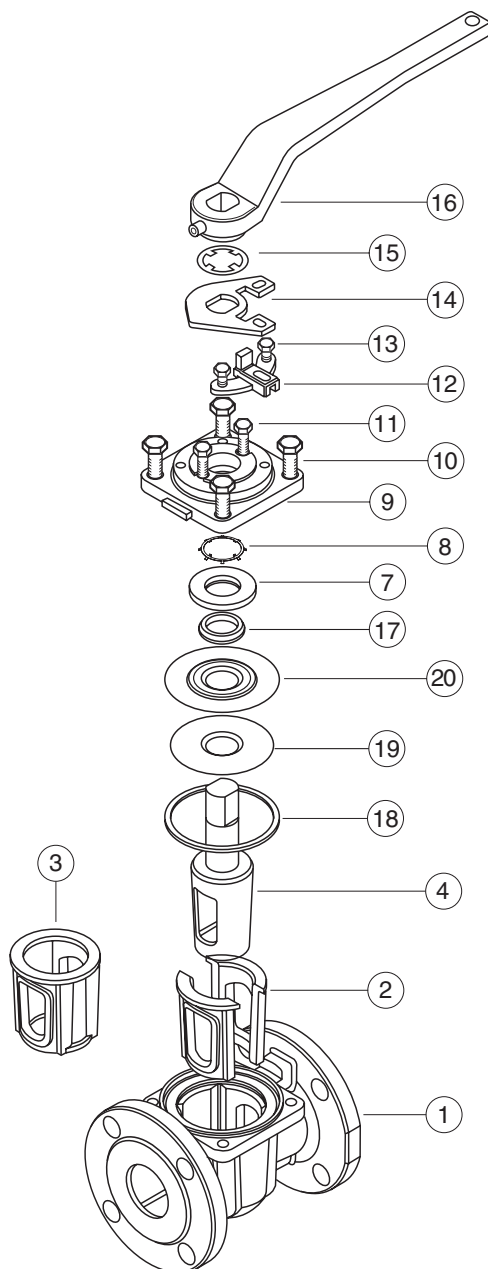

3. The PFA diaphragm (Part 19) is to be flared on a tapered bar just enough to slip over the plug stem (Fig. VI-2)

FIGURE VI-2

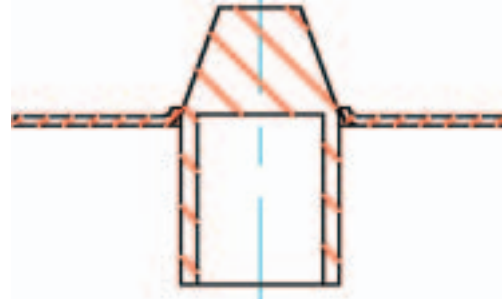

4. The PFA diaphragm is placed over the plug stem with the lip down using the diaphragm guide (Figure VI-3). **The plug stem should be checked for nicks before installing the PFA diaphragm.** Nicks on this surface could result in scratches on the lip of the diaphragm.

FIGURE VI-3

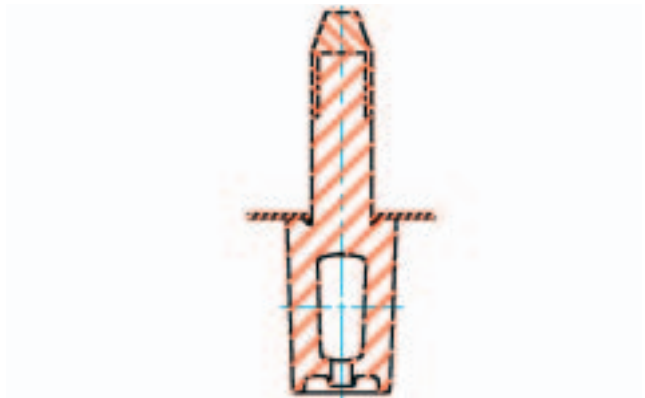

5. The metal diaphragm (Part 20) is placed over the plug stem just far enough to enlarge the ID to conform to the plug stem and then removed (Figure VI-4).

FIGURE VI-4



SECTION VI

6. The metal diaphragm is removed from and replaced on the plug stem with the ID lip down. (Figure VI-5)

FIGURE VI-5

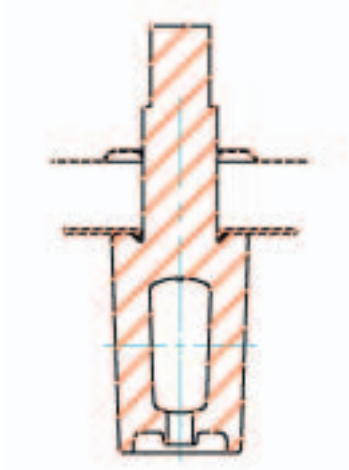

7. The Grafoil packing ring (Part 17) is placed over the stem (Figure VI-6).

FIGURE VI-6

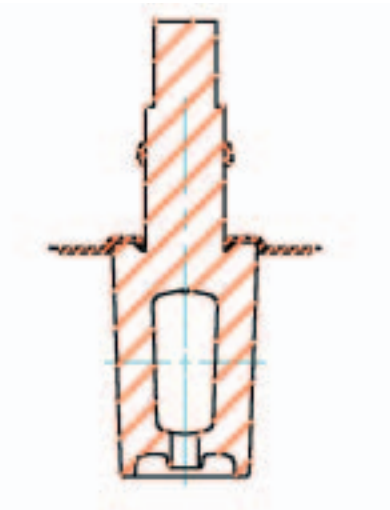

8. The thrust gland (Part 7) is then assembled over the plug and driven into place using the thrust gland guide, part series BY90431 and arbor press. (Figure VI-7)

FIGURE VI-7

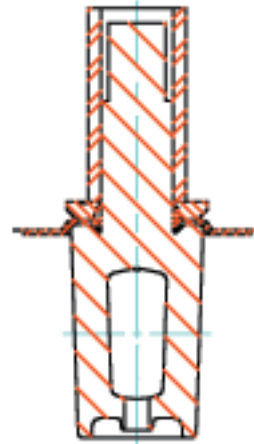

9. The entire assembly is turned over and the Grafoil gasket (Part 18) placed on the metal diaphragm (Figure VI-8). A small amount of rubber cement is placed on the Grafoil in several places to cause it to adhere to the metal diaphragm.

FIGURE VI-8

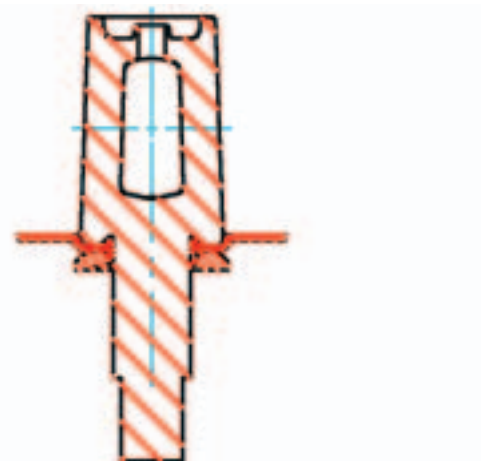

10. Continue to assemble the valve per Section V-A, beginning at step 6.



Flowserve has the answer to your corrosion resistant, quarter-turn valving needs.

Clockwise from top right.

Durco® BTV-2000

PTFE or UHMWPE lined
chemical service valve

Atomac®

Lined ball valves

- ANSI/ISO, standard and full port
- Specialty valves
- Valve products and accessories

Durco® SleeveLine®

Non-lubricated, PTFE-sleeved
plug valves

- G4 Isolation
- G4E – DIN Mounting Pad
- G4 Marathon™
- TSG4 Severe Service

Durco® T-Line®

Non-lubricated, PTFE-lined
plug valves

Big Max® Butterfly

High performance valves

Durco® Microfinish™

Alloy ball valves

Automax®

Valve automation
systems

- Actuators
- Controls with
smart technology
- Accessories

For more information, contact:



Flowserve Corporation
Flow Control Division
1978 Foreman Drive
Cookeville, Tennessee 38501
Phone: 931 432 4021
Fax: 931 432 3105
www.flowserve.com



Or Consult Your Local Stocking Distributor

Flowserve Ahaus GmbH
Von Braun Straße 19a
D-48683 Ahaus
Germany
Phone: +49 2561 686-0
Fax: +49 2561 686-39

Flowserve Pte. Ltd.
12 Tuas Avenue 20
Republic of Singapore 638824
Phone: 65 862 3332
Fax: 65 862 2800

Printed in U.S.A.
August 2002
© Flowserve Corporation