

INSTALLATION, OPERATING AND MAINTENANCE INSTRUCTIONS

**SLEEVELINE[®]
TSG4 SEVERE
SERVICE
PLUG VALVES**

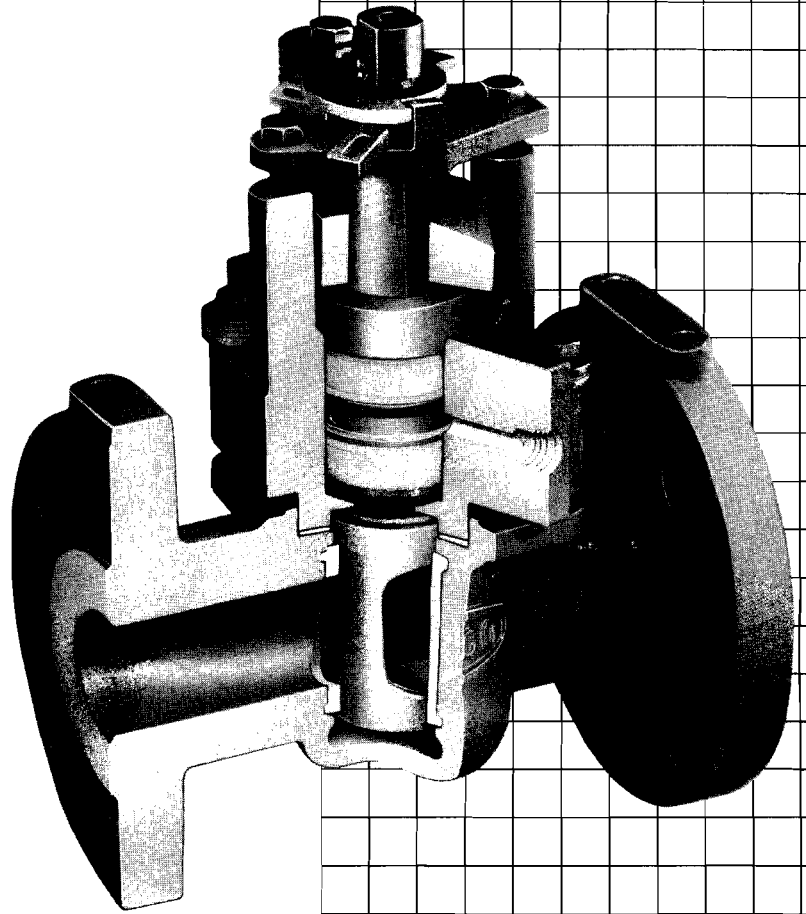

FOREWORD

The Duriron Company, Inc., Valve Division has established this Installation, Operating, and Maintenance Manual to facilitate field installation, operation and repair of TSG4 valves.

It is recommended that questions or concerns involving the processes described in this manual be directed to the

local Sales Representative of The Duriron Company, Inc. Part numbers referenced in the following sections are available from The Duriron Company, Inc., Valve Division.

Only Duriron replacement repair parts and assembly tooling made or designed by The Duriron Company should be used.

TABLE OF CONTENTS

Section	Title	Page
	Foreword	
I.	Installation Instructions—Flanged and Welded TSG4 Valves	2
II.	Figure Numbers, Materials & Parts List	3
III.	Operating Instructions & Parts List	5
IV.	Valve Disassembly—	7
V.	A. Valve Assembly— $\frac{1}{2}$ " & $\frac{3}{4}$ "	7
	B. Valve Assembly—1"–6"	10
VI.	Recommended Spare Parts	12

SECTION I

Installation Instruction—Flanged and Welded TSG4

FLANGED:

Installation of Duriron flanged valves is best accomplished by locating valves in pipeline flanges, assuring all corrosion and foreign material are removed from pipe flange and then center gaskets with the valve flanges. Fasteners or taper pins should be used to align holes and locate gaskets. Fasteners should be tightened to the corresponding valve and fastener size.

WELDED:

The Duriron Company, Inc., Valve Division recommends using only qualified welding procedures and personnel for weld installation of TSG4 valves.

The following precautions should be observed:

1. The valve should be inspected prior to welding to assure that no foreign materials obstruct the flow passageway and that the weld preparations are free of corrosion and physical damage.
2. The valve should be in the open position while being welded. Open position is when the flow indicator on the plug stem is pointing in the direction of the pipeline.

3. Valves of the TSG4 style contain various seal materials which have a maximum temperature limitation. (Refer to Table 1.1 for temperature limitations.) The valve body sleeve area should not exceed this temperature during welding including preheats, interpasses, or post weld heat treatments as applicable.
4. Leak-off or buffering connections should be installed after the valve has been welded into the pipeline. A suitable thread sealant is recommended for installing such connections.

TABLE 1:1 TEMPERATURE LIMITATIONS	
MATERIAL DESCRIPTION	MAXIMUM SERVICE TEMPERATURE
Ultra High Molecular Weight Polyethylene (UMPE)	200°F (93°C)
Tetrafluoroethylene Polymer (PTFE)	400° (204°C)
Durlon 2	400° (204°C)
Duriron Durco 82 (DU-82)	275°F (135°C)

DURCO TSG4 Series Valve Figure Numbers

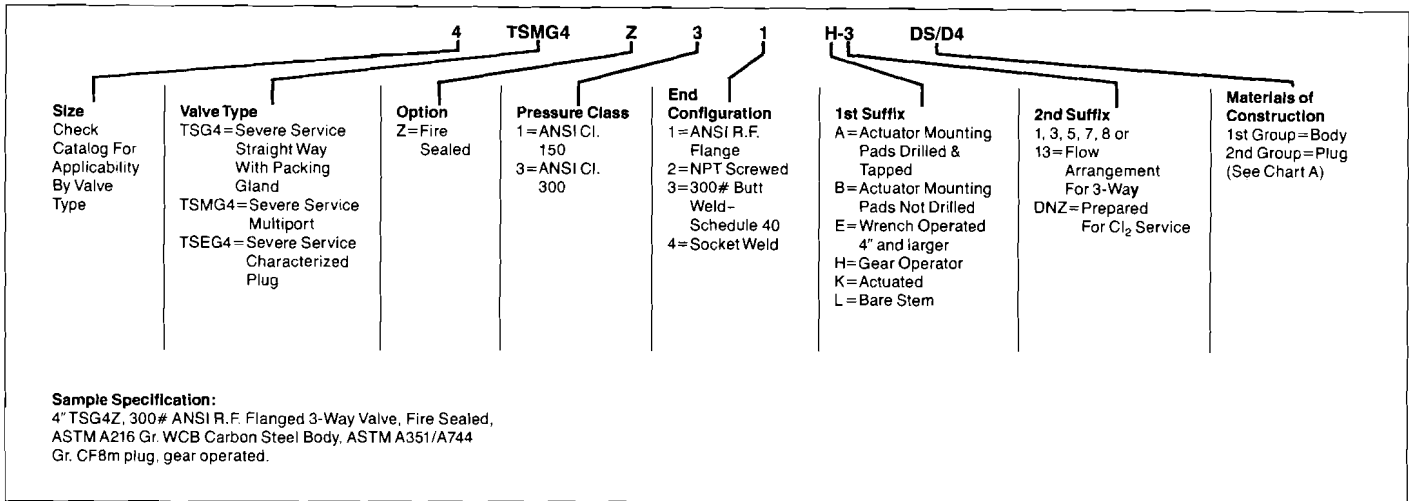

Materials Selection Chart A

DI =	ASTM A395 Ductile Cast Iron
DINI =	Ductile Cast Iron Nickel Plated (Plug Only)
DS =	ASTM A216 Gr. WCB (Cast Steel)
DSNI =	Cast Steel Nickel Plated (Plug Only)
D2 =	ASTM A351/A744 CF8 (304 S.S.)
D2L =	ASTM A351/A744 CF3 (304L S.S.)
D4 =	ASTM A351/A744 CF8M (316 S.S.)
D4L =	ASTM A351/A744 CF3M (316L S.S.)
DV =	Durcomet 5 (High Silicon Stainless Steel)
CD =	ASTM A351/A744 CD4M Cu (Durcomet 100)

D20 =	ASTM A351/A744 CN-7M (Durimet 20)
DIN =	ASTM A494 Gr. CY-40 (Inconel 600) ¹
DM =	ASTM A494 Gr. M35-2 (Monel 400) ²
DMM =	ASTM A494 Gr. M35-1 (Monel 400) ²
DNI =	ASTM A494 Gr. CZ-100 (Nickel 200)
DC2 =	ASTM A494 Gr. N-7M (Hastelloy B)
DC3 =	ASTM A494 Gr. CW-6M (Hastelloy C) ³
Ti =	ASTM B367 Gr. C-3 (Titanium)
Zr =	ASTM B752 Gr. 702C (Zirconium)

1. Registered trademark of the International Nickel Company, Inc.

2. Registered trademark of the International Nickel Company, Inc.

3. Registered trademark of the Cabot Corporation

TSG4 Valve Parts List

ITEM	DESCRIPTION	NUMBER REQ'D
1	Body	1
2	Plug	1
● 3	Sleeve	1
● 4	Packing Set	1
5	Packing Adjuster	1
6	Packing Gland	1
7	Belleville Washers, Packing	24
8	Packing Adjuster Fasteners	2
9	Top Cap	1
10	Top Cap Fasteners	4
11	Plug Adjuster	1
12	Plug Adjuster Fasteners	2
13	Stop Collar	1
14	Belleville Washers, Top Cap	16
15	Stop Collar Retainer	1
● 16	Grounding Spring	1
17	Plug Gland	1
● 18	Thrust Washer	1
● 19	Plug Bearing	1
● 20	Top Cap Gasket	1

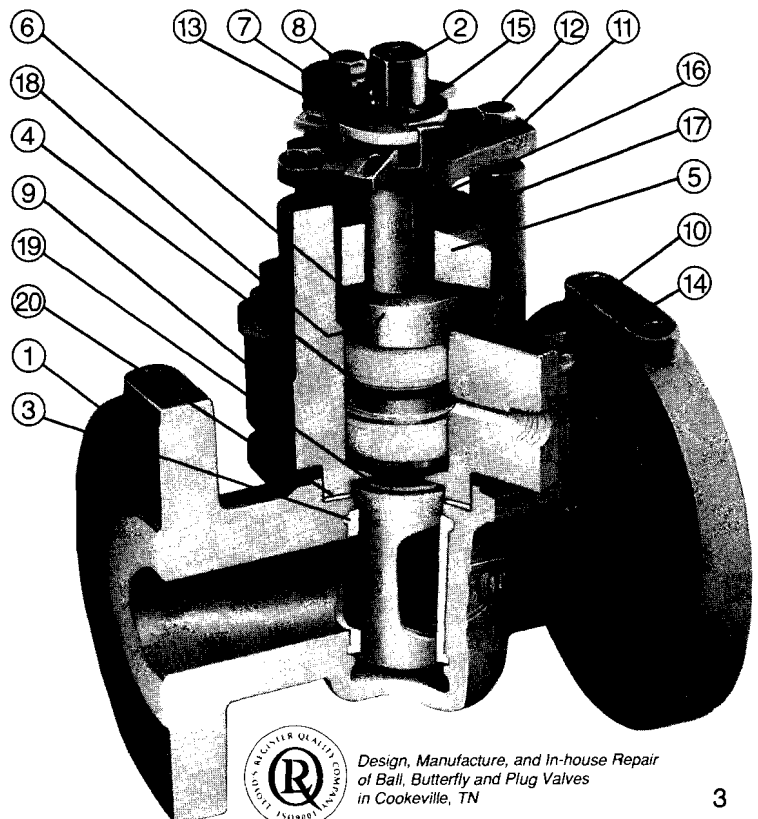

Design, Manufacture, and In-house Repair of Ball, Butterfly and Plug Valves in Cookeville, TN

● Recommended Spare Parts

Stuffing Box Options:

The Durco TSG4 valve will accommodate standard packing of most manufacturers. Our standard is PTFE cup and cone.

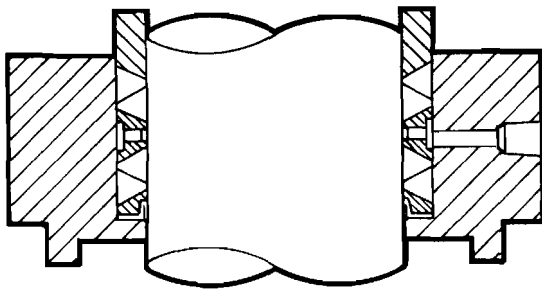

Cup and cone with lantern ring and reverse lip diaphragm

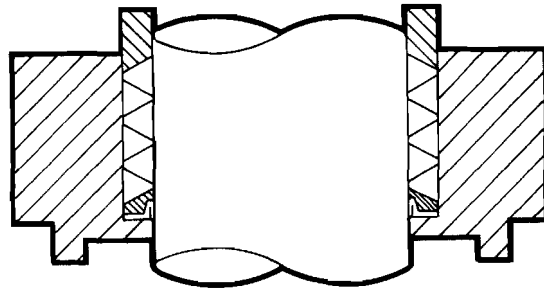

Cup and cone with reverse lip diaphragm

Fire Sealed Options:

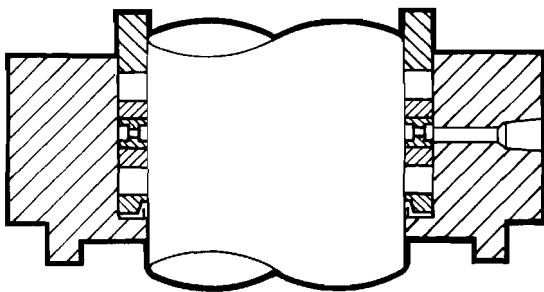

Compression fire seal packing set* die formed flexible graphite rings and lantern ring** between braided Grafoil® with reverse lip diaphragm

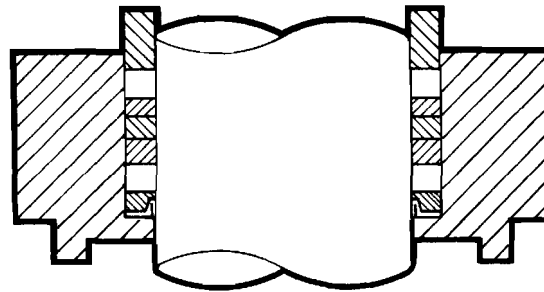

Compression fire seal packing set* die formed flexible graphite rings between braided Grafoil® with reverse lip diaphragm

Stuffing Box Dimensions

Valve Size	1/2-3/4	1	1 1/2	2	3	4	6	8
I.D.	.875	1.250	1.250	1.625	2.000	2.500	3.250	4.000
	.870	1.245	1.245	1.620	1.995	2.495	3.245	3.995
O.D.	1.625	2.005	2.005	2.380	2.755	3.255	4.005	4.755
	1.630	2.000	2.000	2.375	2.750	3.250	4.000	4.750
Depth	2 1/16	2 1/16	2 1/16	2 1/16	2 1/16	2 3/32	2 1/16	2 1/16

*Specify whether PTFE for standard use or Grafoil® for fire seal use.

**Shown with optional tap in top cap (bonnet).

* Grafoil is a registered trademark of Union Carbide.

Envelope Dimensions

Valve Size in. (mm)	1/2	3/4	1	1 1/2	2	3	4	6	8
Dist. from ϕ of Pipe to Top of valve	6.343	6.343	6.937	7.250	7.625	8.968	10.843	12.688	17.156

Operation Instructions And Parts List For TSG4 Valves

Part reference cited in this section can be identified using Figures 1 through 3 and the material list.

Periodic maintenance requirements for TSG4 valves may vary due to operating conditions of the process. Factors such as operating temperature and pressure, flowstream, solid content and constitution, and frequency of cycling (open to close) can greatly influence valve performance and maintenance requirements.

Seal wear and degradation is compensated by correctly adjusting appropriate parts. For TSG4 valves, three possible leak paths occur; for each leak path there exists a means of adjustment. Leak paths are:

1. BONNET
2. STEM
3. LINE (through)

Each leak path and corresponding adjustment shall be treated separately.

1. BONNET

Leakage due to thermal cycling (gradients) and frequent high pressure cycling is stopped by snugging the top cap fasteners (item 10 in Figure 3) in a "criss-cross" manner (1-3-2-4) per Fig. 3. This adjustment is most effective when the valve is not pressurized. It is important that the top cap fasteners not be torqued above the level specified in Table 1.

2. STEM

Leakage due to wear of the service packing is stopped by tightening the packing adjuster fasteners (item 8 in Figure 1) in 1/2 turn increments. The fasteners should be tightened evenly. The packing adjuster fasteners should not be tightened above the torque level specified in Table 3 of the seal replacement section of this manual. If possible, the valve should be operated between adjustments, to assure that the plug stem will not be "frozen" due to overloading the stem packing. If stem leakage persists, or the packing adjuster fasteners bottom out, the stem packing should be replaced.

3. LINE (through)

Through leakage due to wear or damage to the valve sleeve, or primary seal can be stopped by tightening the plug adjuster fasteners (item 12 in Figure 2) in 1/4 turn increments. The fasteners should be tightened evenly. If possible, the valve should be operated between adjustments to assure that the plug has not been forced into the sleeve excessively, producing an unnecessary valve operating torque. Should the valve be leaking excessively after numerous adjustments, the sleeve will require replacement.

Table #1a *Apply Loctite® 242 to fastener threads, top cap only.
Torque Required On Top Cap Fasteners Of Class 150 TSG4 Valves

VALVE SIZE	1/2-3/4"	1"	1 1/2"	2"	3"	4"	6"	8"
TORQUE (ft-lbs)	7	7	7	12	21	31	62	62

Table #1b *Apply Loctite® 242 to fastener threads, top cap only.
Torque Required On Top Cap Fasteners Of Class 300 TSG4 Valves

VALVE SIZE	1/2-3/4"	1"	1 1/2"	2"	3"	4"	6"	8"
TORQUE (ft-lbs)	7	13	13	20	31	62	125	115

Table #2
Torque On Plug Adjuster Fasteners Of TSG4 Valves, 150# And 300#

VALVE SIZE	1/2-3/4"	1"	1 1/2"	2"	3"	4"	6"	8"
TORQUE (in-lbs)	10	35	35	35	50	80	180	372

Table #3
Torque On Packing Adjuster Fasteners Of TSG4 Valves, 150# And 300#

VALVE SIZE	1/2-3/4"	1"	1 1/2"	2"	3"	4"	6"	8"
TORQUE (in-lbs)	70	70	70	70	150	200	240	660

®Loctite is a registered trademark of the Loctite Corp.

Materials Of Construction

TSG4 VALVES

● Recommended Spare Parts

ITEM	DESCRIPTION	NUMBER REQ'D	MATERIAL
1	Body	1	ALY*
2	Plug	1	ALY*
● 3	Sleeve	1	TFE
● 4	Packing Set	1	TFE**
5	Packing Adjuster	1	D100
6	Packing Gland	1	304SS
7	Belleville Washers	24	17-7 PH E.N.C.***
8	Packing Adj. Fastener	2	B7/B8
9	Top Cap	1	ALY*
10	Top Cap Fastener	4	B7/B8
11	Plug Adjuster	1	D100
12	Plug Adjuster Fastener	2	B7/B8
13	Stop Collar	1	Cd Plated Steel
14	Belleville Washers	16	17-7 PH E.N.C.***
15	Stop Collar Retainer	1	302SS
● 16	Grounding Spring	1	302SS
17	Plug Gland	1	304SS
● 18	Thrust Washer	1	Glass Filled TFE
● 19	Plug Bearing	1	TFE
● 20	Gasket—Top Cap	1	TFE**

*Carbon Steel, 316SS, Durimet 20, Monel, Chlorimet 3. Plug and Topcap are typically the same alloy unless otherwise specified.

**Part Nos. 4 & 20 are Grafoil® on Fire Sealed TSG4Z.

***Part Nos. 7 & 14 are normally not used on Fire Sealed TSG4Z.

† Grafoil is a registered trademark of Union Carbide.

FIGURE 1

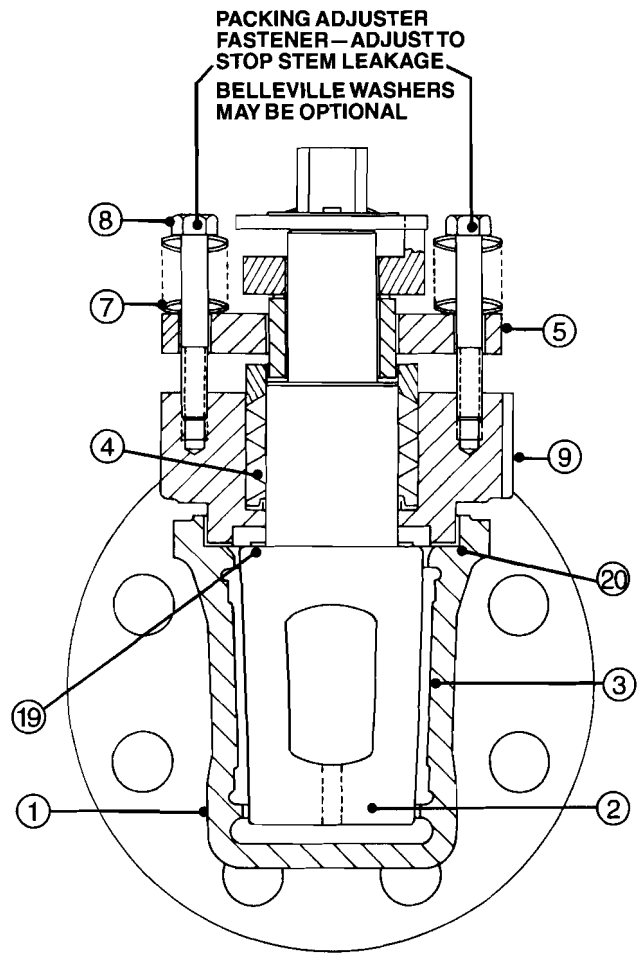

FIGURE 2

PLUG ADJUSTER FASTENER TIGHTEN TO STOP THROUGH (line) LEAKAGE

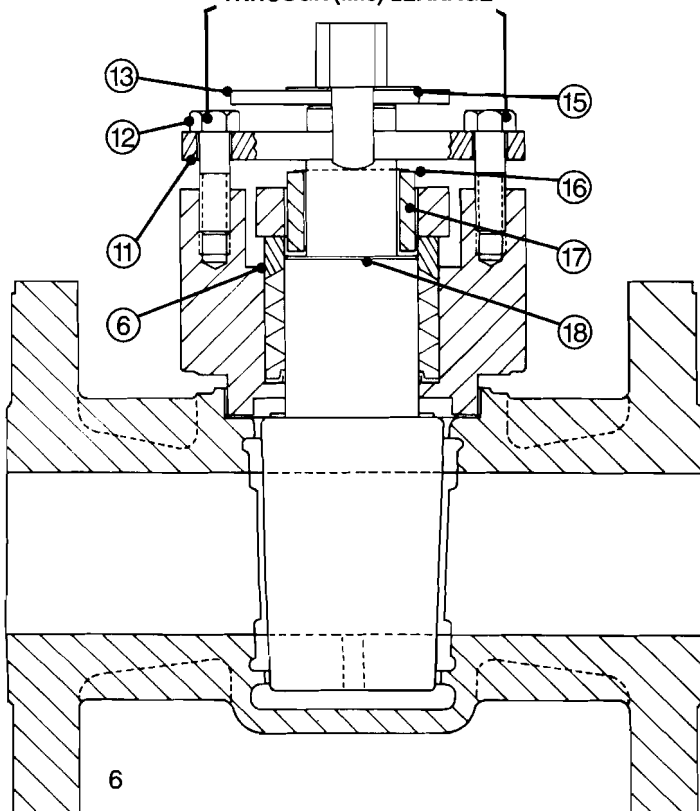
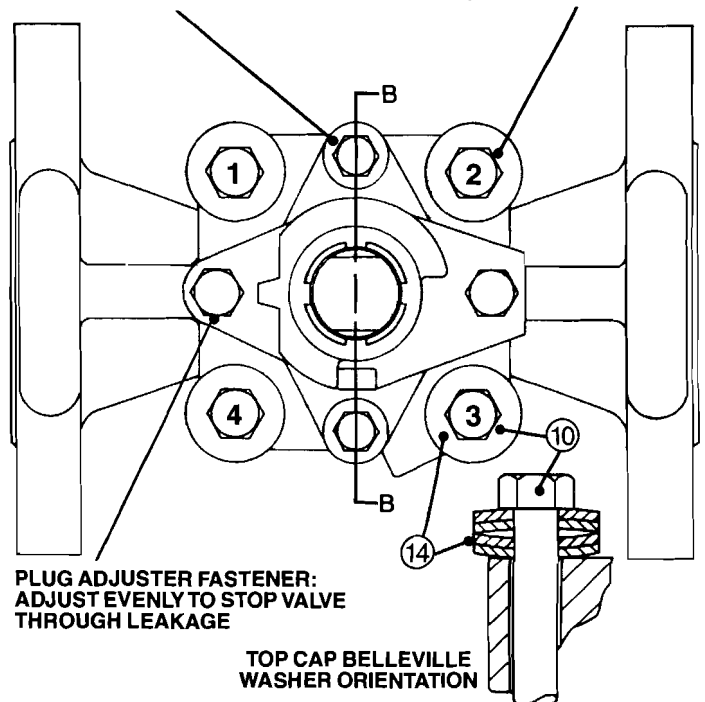

FIGURE 3

PACKING ADJUSTER FASTENER: ADJUST EVENLY TO STOP STEM PACKING LEAKAGE
TOP CAP (bonnet) FASTENER: TIGHTEN EVENLY TO STOP (bonnet) LEAKAGE



Valve Disassembly—TSG4

Recommended Precautionary Measures

1. Valves must be relieved of process fluid and pressure prior to disassembly. Plug should be in the open position.
2. Personnel performing disassembly must be suitably protected and alert for emission of hazardous process fluid.
3. If there is a pipe plug located at the bottom bowl of the valve, DO NOT remove the pipe plug until the valve plug has been removed.

Disassembly Steps

NOTE: Refer to Figures 1, 2, & 3 for parts identification. If an actuator or gearbox operates the valve, alignment marks should be noted to assure correct orientation when reassembled. This may best be accomplished by making matching marks on the plug stem and operator housing with no burrs on the plug stem permitted.

1. Gradually loosen plug adjuster fasteners (Part 12)—DO NOT REMOVE.
2. Turn plug (Part 2) in order to raise the plug to vent any material trapped in the valve (see note below).
NOTE: If there is no upward movement of the plug (Part 2), it will be necessary to devise a method of lifting the plug upward. This may require removal of the valve operator (Step 3). This operation should be undertaken noting the above precautionary measures. Methods of plug removal must include protective measures on plug stem and plug end.
3. **WARNING: Do not loosen or remove top cap fasteners (Part 10) when removing an operator or accessory. Remove the operator by unfastening it from the bracket.**

4. Once the plug (Part 2) has lifted, the adjuster fasteners (Part 12) can be completely removed.
5. Loosen and remove the packing adjuster fasteners (Part 8).
6. Gradually loosen but DO NOT REMOVE all of the top cap fasteners (Part 10). Turn the plug until it is loose from the sleeve (Part 3) and all pressure has been vented. (Again, it may be necessary to use a mechanical means to move the plug upwards.)
7. Remove the top cap fasteners (Part 10) and top cap (Part 9).
8. Remove the plug (Part 2) from the body (Part 1).
9. Remove the grounding spring (Part 16) from the plug.
10. Inspect the valve sleeve (Part 3) for wear or damage, especially scratches near the top, bottom, and port areas. If wear or damage is excessive, the sleeve should be replaced.
11. Remove sleeve (Part 3) as follows:
NOTE: Care should be taken not to damage the internal body bore.
 - a. Using a screw driver and mallet, cut the old sleeve through one of the port openings, top and bottom.
 - b. Grasp the sleeve with a pair of pliers while twisting, and lift the sleeve from the body.
12. Thoroughly clean all valve parts with an acceptable cleaner.
13. Inspect parts for damage. Look for marred, scratched, or rough sealing surfaces on the valve plug (Part 2).
NOTE: Reinstallation of damaged or unclean parts will ruin any replacement seals installed into the valve.

SECTION V

A. Valve Assembly— $\frac{1}{2}$ " & $\frac{3}{4}$ " TSG4

1. Apply two coats of Durco Seal 1028B to the inside of the tapered bore in the body and permit to dry before assembly. One coat is such that no metal surface is visible through the coating. RAD-1 material is used for nuclear applications.
2. Assemble sleeve into body with a coining die, part series #BY81917A. Position sleeve in coining die so that sleeve

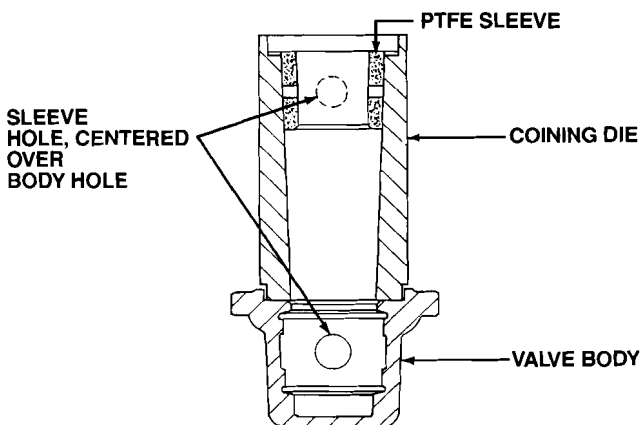

FIGURE VA-1
ASSEMBLE SLEEVE

holes are centered over body ports (Figure VA-1). Place push rod and push rod guide in coining die and push sleeve into body until push rod stops on push rod guide (Figure VA-2).

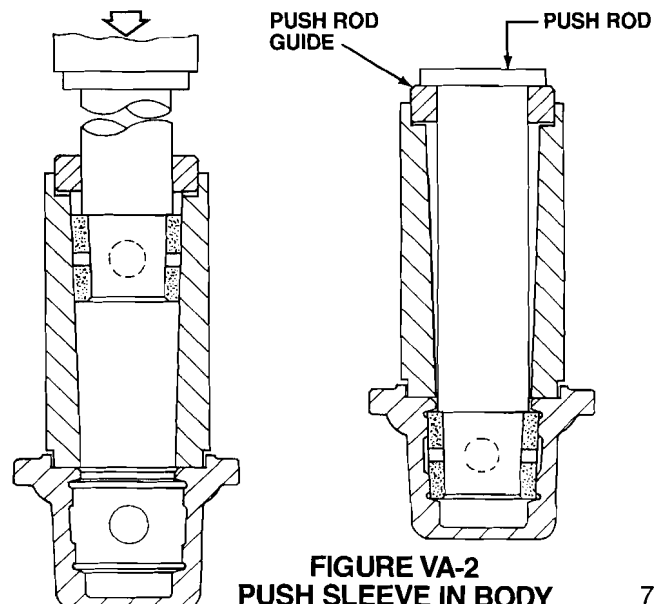

FIGURE VA-2
PUSH SLEEVE IN BODY

SECTION V

- Size sleeve. Check sleeve in body to make sure sleeve holes are still centered on the body ports. Apply a light coat of silicone lubricant to sizing Plug #1 and sizing Plug #2, part series #BY80017B & C. Push sizing Plug #1 into sleeve until the sizing plug flange bottoms against the counterbore of the valve body. Remove #1 sizing plug and now push #2 sizing plug in the same manner, but **HOLD SIZING PLUG IN PLACE** for 15 SECONDS (Figure VA-3).

- Rough Size With Plug #1
- Finish Size With Plug #2 (Hold for 15 Seconds)

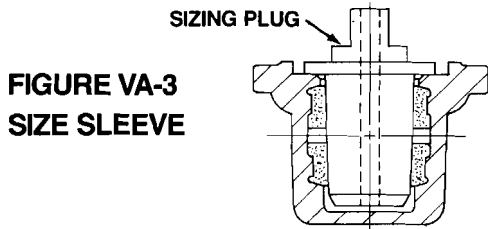

FIGURE VA-3
SIZE SLEEVE

NOTE: The TSG4 top works is to be assembled onto the plug prior to pushing the plug into the sleeve/valve body.

- The plug bearing is to be placed on the plug as shown in (Figure VA-4). The plug stem and the stuffing box counterbore of the top cap must be repolished, if necessary, until a surface finish of 16 RMS is achieved.
- The top cap is placed on the plug as shown in Figure VA-4. Care must be exercised to insure that the plug stem is not scratched as the top cap is lowered onto the plug.

- Install the diaphragm guide over the plug stem. This guide must be used to install the diaphragm. Make sure there are no nicks on the guide. Place the diaphragm over the guide and push downward over the guide. See Figure VA-4. Push the diaphragm down using the diaphragm pusher.

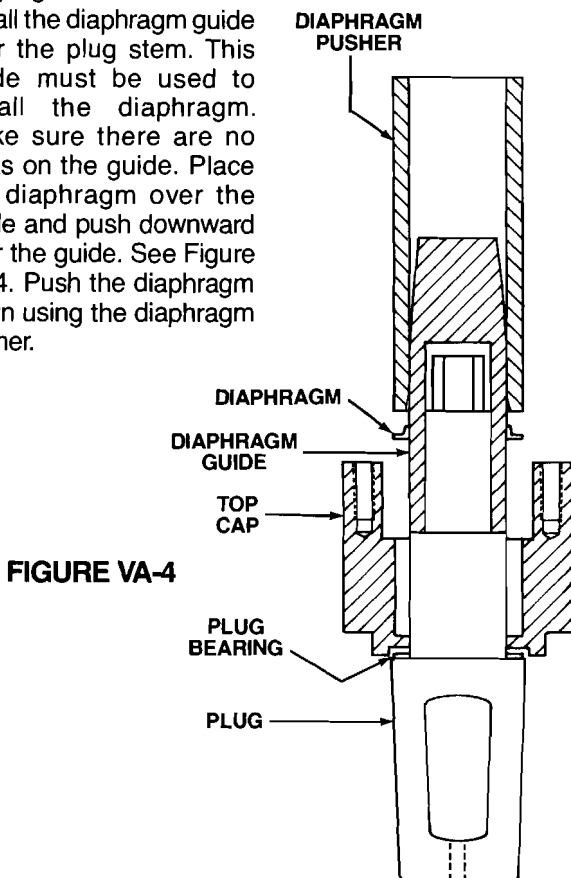

FIGURE VA-4

- Remove the diaphragm guide and pusher from the stem. Place the diaphragm gland over the plug stem. Now locate and seat the diaphragm gland by pushing downward with the diaphragm gland pusher. (An arbor press is required to load the pusher.) See Figure VA-5.

- At this time apply a light coat of silicone to the packing area of the plug stem and the seat area of the top cap stuffing box.

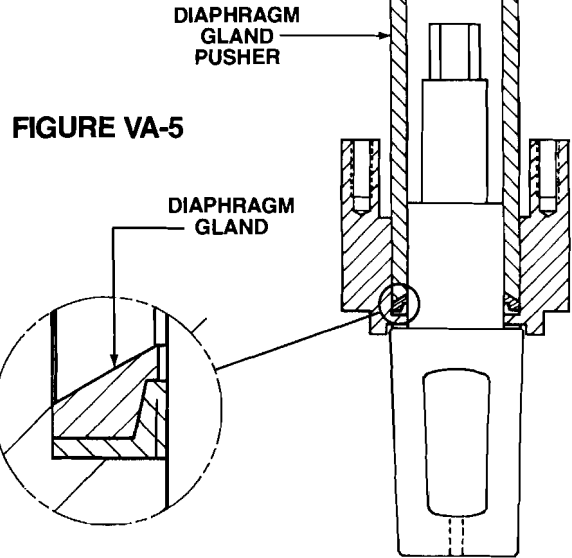

FIGURE VA-5

- The packing is then placed into the stuffing box as shown in Figure VA-6. Several packing orientations are shown in an earlier section. Under no circumstances shall sharp objects such as screw drivers, cold chisels or knives be used to force the packing into the stuffing box. The packing gland may be used to start the packing into the stuffing box.

- Following insertion of the packing set, the diaphragm gland pusher is placed over the plug stem. Seat the packing by loading the gland pusher with an arbor press. The packing may be seated in sections but the gland pusher will only fit a cone ring. It must not be used to seat against a cup. See Figure VA-6. The packing gland is now placed over the plug stem and seated with the arbor press.

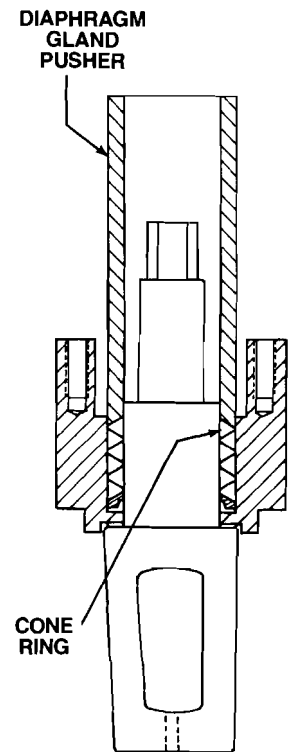

FIGURE VA-6

11. The packing adjuster is placed over the plug stem. Each fastener shall have twelve (12) Belleville washers placed as shown in Figure VA-7. The packing adjuster fasteners should be tightened finger tight. Care should be taken such that the packing adjuster remains level with respect to the top cap.
12. The thrust washer is placed over the plug stem and should lay flat against the plug stem bearing surface as shown in Figure VA-7.

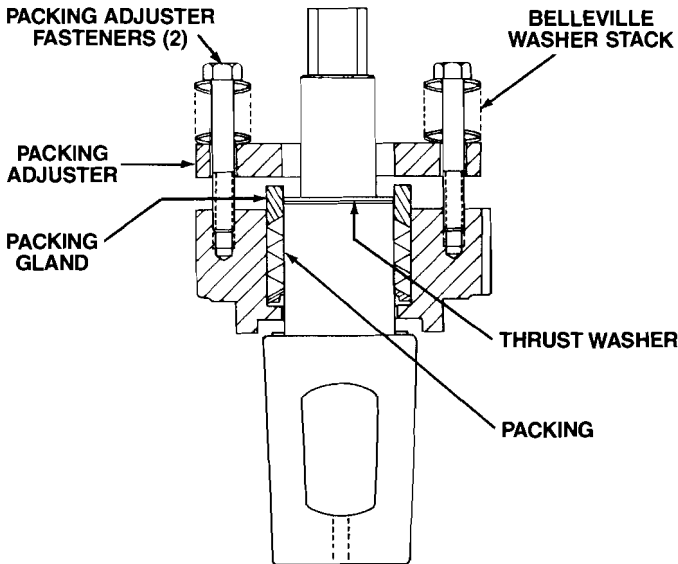

FIGURE VA-7

13. The plug gland is placed over the plug stem. Next, the grounding spring is pushed onto the plug stem. The adjuster with fasteners is placed over the plug stem and secured by the adjuster fasteners shown in Figure VA-8. The adjuster fasteners should be tightened to position the top cap gasket surface in line with the flat surface which the plug bearing rests on as shown in Figure VA-8.

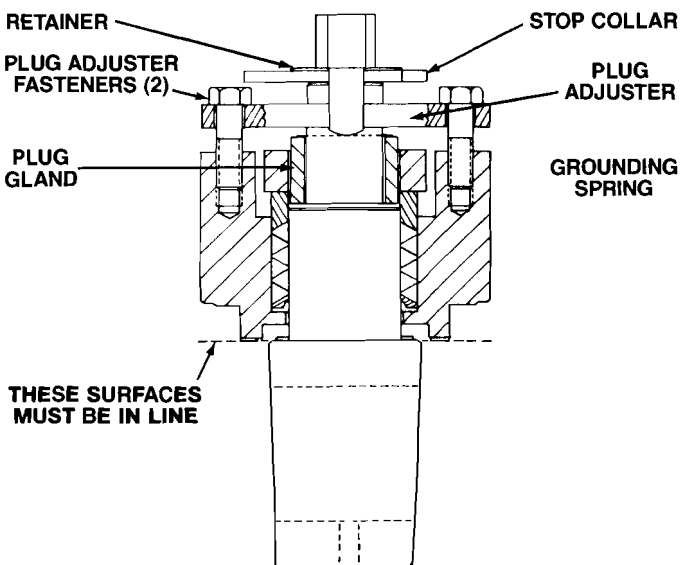
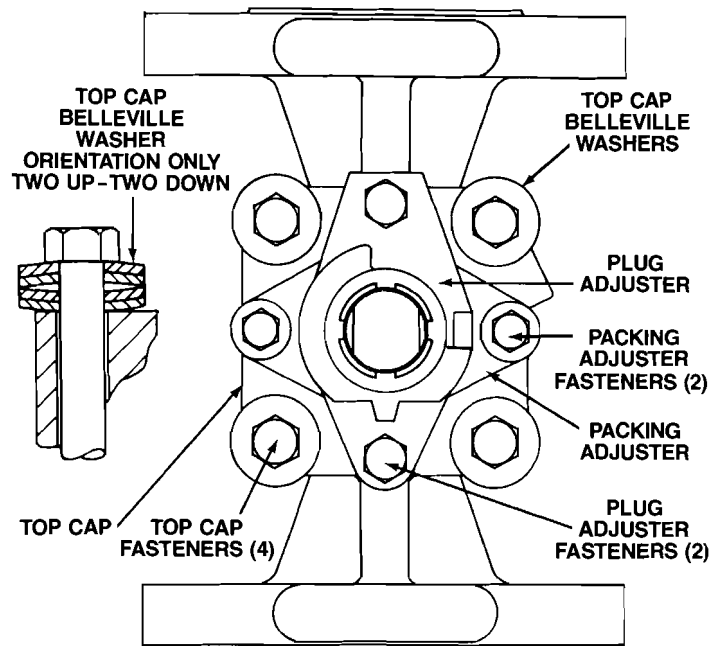

FIGURE VA-8

14. Place the top cap gasket into the valve body flange counterbore.
15. Apply a thin, even film of silicone (General Electric Viscasil 10,000 or equal) to the entire outside surface of the 2° plug taper.
16. The top works is then placed onto the valve body and oriented as shown in Figure VA-9. The plug is then pressed into the sleeve with the aid of an arbor press. The press must provide sufficient force to depress the plug, allowing the gasket surface of the top cap to bottom against the gasket counterbore. The valve must remain in the arbor press for steps 16 thru 19.
17. The top cap fasteners with four (4) Belleville washers each (Figure VA-9 for top cap Belleville washer orientation) should be installed at this time. Do not tighten the top cap fasteners more than finger tight.



ORIENTATION OF THE TOP CAP ON THE VALVE BODY
 FIGURE VA-9

18. Tighten the packing adjuster fasteners in a manner such that the packing adjuster does not "tilt". The torque on the packing adjuster fasteners should be 70 in-lbs. See Figure VA-9.
19. Tighten the top cap fasteners in a crisscross fashion to 85 in-lbs.
20. At this time, remove the valve from press.
21. Loosen the plug adjuster fasteners and operate the plug several times.
22. Tighten the plug adjuster fasteners to 10 to 12 in-lbs. Install stop collar and retainer ring.
23. Operate the plug several times. It will be difficult to turn at first, but will then loosen and turn freely.
24. Pressure testing of the assembled valve should be done at this time. Any additional valve adjustment that might be needed to hold the specified pressure should be made at this time. The valve is now ready for installation.

SECTION V

B. Valve Assembly—1"–6" TSG4

Due to the tooling and associated equipment required (presses, fixtures, etc.) to rebuild 8" TSG4 size valves, it is highly recommended they be returned to the factory for repair and rebuild. Many valves made by The Duriron Company, Inc., handle corrosive chemicals which may be injurious to property or personnel. Valves returned without proper attention given to the safety requirements will be shipped back to the consignor collect.

NOTE: Item number reference is shown on page 6 (Figures 1, 2 & 3).

1. Apply two coats of Durco Seal 1028B to the inside of the tapered bore in the body and permit to dry before assembly. One coat is such that no metal surface is visible through the coating. RAD-1 material is used for nuclear applications.
2. Apply a light coating of oil or silicone to the interior of the coining die or to the O.D. of the sleeve. Position the sleeve in the coining die, part series #BY79542A, so that the diagonal opposite sides of the sleeve port will lock behind the metal lips in the body (Figure VB-2). The sleeve is then pushed directly through the coining die into the valve body until the sleeve drops below the top counterbore of the valve body (Figure VB-1).

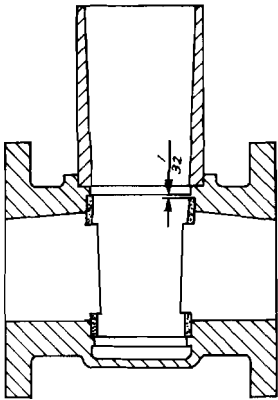
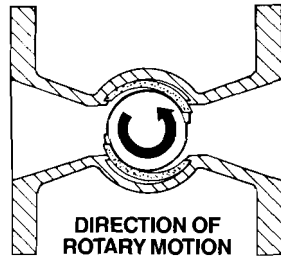

FIGURE VB-1

Push sleeve directly through coining die until sleeve drops below top counterbore of the valve body.

3. A special plug, part series #BY79664A, containing retractable or removable blades is lowered into the body with the blades retracted or removed. The blades are then installed or extended and a rotary motion is applied to the plug engaging the two remaining diagonal opposite sleeve port openings and pulling them until they fall behind the body port lips. The plug is then rotated back to its original position, and the blades are then removed



DIRECTION OF ROTARY MOTION

FIGURE VB-2

A special plug with retractable or removable blades engages the two remaining sleeve ports and pulls them until they fall behind the body port lips.

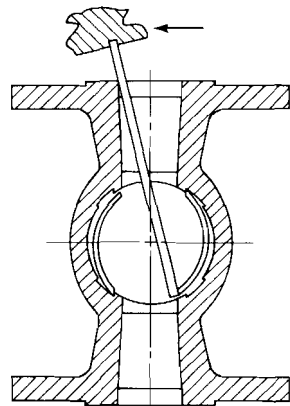

FIGURE VB-2a

Optional assembly operation for 1" & 1½" TSG-4 Valves

Care must be exercised to insure that the bar does not slip and gouge or tear the sleeve.

or retracted. The plug is then removed from the body (Figure VB-2). In the 1" and 1½" sizes, a bar may be substituted for the locking plug. See Figure VB-2a for a description of this operation.

FIGURE VB-3

The sizing plug is pushed into the sleeve until the sizing plug flange bottoms against the counterbore of the valve body.

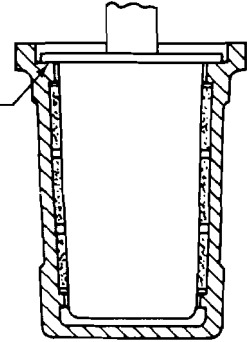

4. Apply a thin film of oil on the sizing plug, part series #BY79555A, and push it into the sleeve until the sizing plug flange bottoms against the counterbore of the valve body (Figure VB-3). Allow the sizing plug to remain in this position for one minute.

NOTE: The TSG4 top works is to be assembled onto the plug prior to pushing the plug into the sleeve/valve body.

5. The plug bearing is to be placed on the plug as shown in Figure VB-4. The plug stem and the stuffing box counterbore of the top cap must be repolished, if necessary, until a surface finish of 16 RMS is achieved.
6. The top cap is placed on the plug as shown in Figure VB-4. Care must be exercised to insure that the plug stem is not scratched as the top cap is lowered onto the plug.
7. Install the diaphragm guide over the plug stem. This guide must be used to install the diaphragm. Make sure there are no nicks on the guide. Place the diaphragm over the guide and push downward over the guide. See Figure VB-4. Push the diaphragm down using the diaphragm pusher.

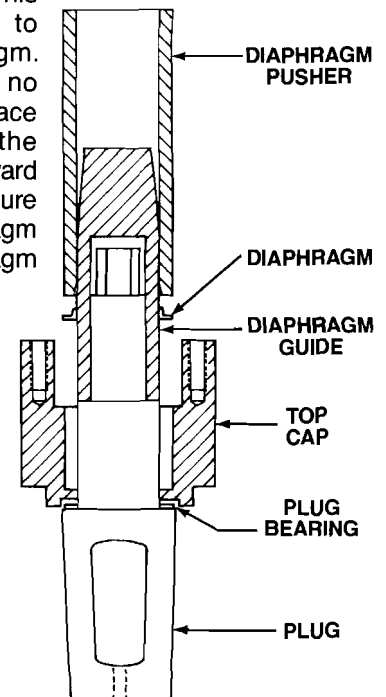

FIGURE VB-4

8. Remove the diaphragm guide and pusher from the stem. Place the diaphragm gland over the plug stem. Now locate and seat the diaphragm gland by pushing downward with the diaphragm gland pusher. (An arbor press is required to load the pusher.) See Figure VB-5.

9. At this time apply a light coat of silicone to the packing area of the plug stem and the seat area of the top cap stuffing box.

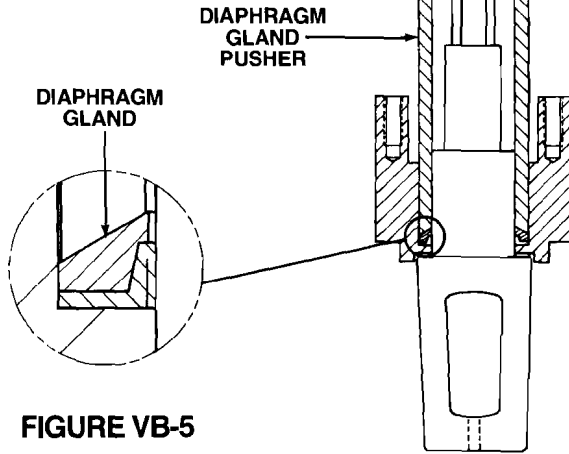

FIGURE VB-5

10. The packing is then placed into the stuffing box shown in Figure VB-6. Several packing orientations are shown in an earlier section. Under no circumstances shall sharp objects such as screw drivers, cold chisels or knives be used to force the packing into the stuffing box. The packing gland may be used to start the packing into the stuffing box.

11. Following insertion of the packing set, the diaphragm gland pusher is placed over the plug stem. Seat the packing by loading the gland pusher with an arbor press. The packing may be seated in sections but the gland pusher will only fit a cone ring. It must not be used to seat against a cup. See Figure VB-6. The packing gland is now placed over the plug stem and seated with the arbor press.

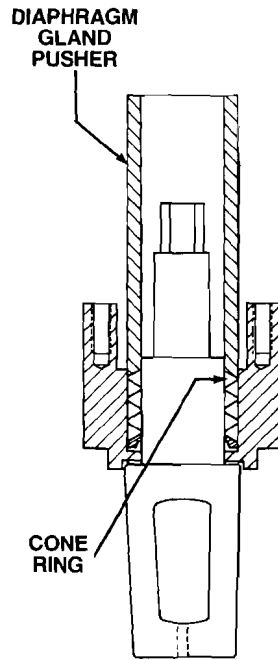

FIGURE VB-6

12. The packing adjuster is placed over the plug stem. Each adjuster fastener shall have twelve (12) Belleville washers placed as shown in Figure VB-7. The packing adjuster fasteners should be tightened finger tight. Care should be taken such that the packing adjuster remains level with respect to the top cap.

13. The thrust washer is placed over the plug stem and should lay flat against the plug stem bearing surface as shown in Figure VB-7.

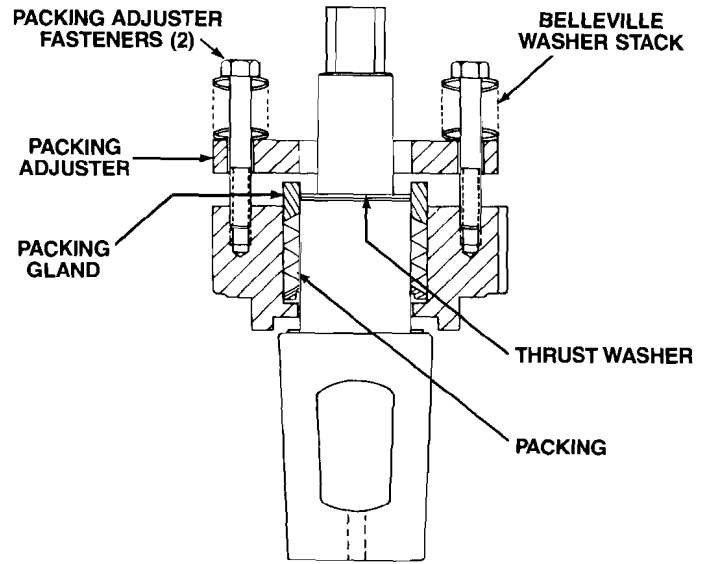

FIGURE VB-7

14. The plug gland is placed over the plug stem. Next, the grounding spring is pushed onto the plug stem. The adjuster with fasteners is placed over the plug stem and secured by the adjuster fasteners shown in Figure VB-8. The adjuster fasteners should be tightened to position the top cap gasket surface in line with the flat surface which the plug bearing rests on as shown in Figure VB-8.

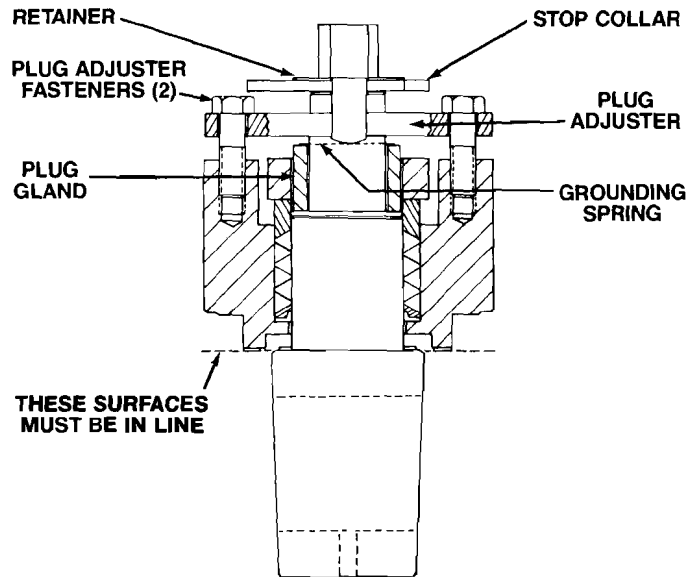

FIGURE VB-8

15. Place the top cap gasket into the valve body flange counterbore.

16. Apply a thin, even film of silicone (General Electric Viscasil 10,000 or equal) to the entire outside surface of the 2° plug taper.

SECTION V

B. Valve Assembly—1"–6" TSG4

17. The top works is then placed onto the valve body and oriented as shown in Figure VB-9. The plug is then pressed into the sleeve with the aid of an arbor press. The press must provide sufficient force to depress the plug, allowing the gasket surface of the top cap to bottom against the gasket counterbore. The valve must remain in the arbor press for steps 17 thru 20.
18. The top cap fasteners with four (4) Belleville washers each (Figure VB-9 for cap Belleville washer orientation) should be installed at this time. Do not tighten the top cap fasteners more than finger tight.
19. Tighten the packing adjuster fasteners in a manner such that the adjuster does not "tilt." The torque on the packing adjuster fasteners should be as specified in Table #3.
20. Tighten the top cap fasteners in a crisscross fashion to the values shown in Table #1a or #1b as appropriate.
21. At this time, remove valve from the arbor press.
22. Loosen the plug adjuster fasteners and operate the plug several times.
23. Tighten the plug adjuster fasteners to the values shown in Table #2 or until the plug port is flush with the body port. Install stop collar and retainer ring.
24. Operate the plug several times. It will be difficult to turn at first, but will then loosen and turn freely.
25. Pressure testing of the assembled valve should be done at this time. Any additional valve adjustment that might be needed to hold the specified pressure should be made at this time. The valve is now ready for installation.

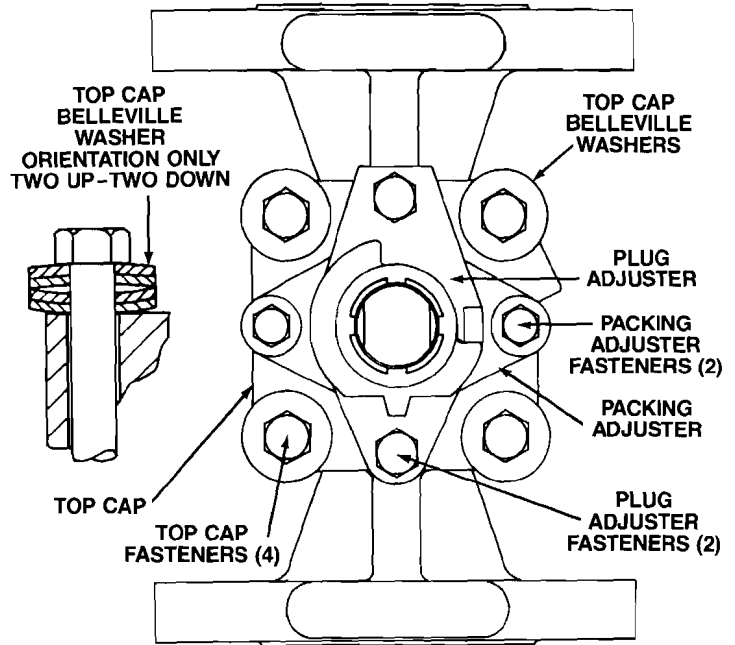

FIGURE VB-9

ORIENTATION OF THE TOP CAP ON THE VALVE BODY

VALVE REPAIR SERVICE

For the convenience of our customers, The Duriron Company, Inc., maintains a complete valve repair facility in our Cookeville, Tennessee factory. For information on how to capitalize on this service for any of your Durco valves, call us at (615) 432-4021.

Or Consult Your Local Stocking Distributor

THE DURIRON COMPANY, INC.
VALVE DIVISION
Cookeville, Tennessee 38501
(615) 432-4021

